



Committee of Adjustment

Agenda

Date: June 3, 2026
Time: 5:30 pm
Location: Council Chambers, City Hall, second floor

Pages

1. Call to Order

2. Land Acknowledgement

Burlington as we know it today is rich in history and modern traditions of many First Nations and the Métis. From the Anishinaabeg to the Haudenosaunee and the Métis – our lands spanning from Lake Ontario to the Niagara Escarpment are steeped in Indigenous history.

The territory is mutually covered by the Dish with One Spoon Wampum Belt Covenant, an agreement between the Iroquois Confederacy, the Ojibway and other allied Nations to peaceably share and care for the resources around the Great Lakes.

We acknowledge that the land on which we gather is part of the Treaty Lands and Territory of the Mississaugas of the Credit.

3. Roll Call

4. Declarations of Interest

5. Addendums

6. Request for Deferrals

7. Consent Items

Applications placed on the Consent Agenda are of a routine nature, require no discussion and/or debate, have staff support, have received no objections as a result of the public notice or delegation requests, and are accepted by Committee members as meeting the four tests of the Planning Act. All other applications are placed on the Regular Agenda

7.1 NONE

8. Regular Items

8.1 1238 Bellview Street_A-010-2026

1 - 31

Proposal:

The applicant is proposing to revise the existing scope of work to alter the exterior finish from stucco to ACM panels, provide a new roof top access addition, and include a ramp access in side yard.

Variance required:

1. To permit a building height of 8.7 m instead of the maximum permitted 7.0 m for a proposed two storey dwelling with a flat roof and roof access.

9. Other Business

9.1 Correspondence

9.2 Items for Discussion

9.3 Date of Next Meeting

9.4 Motion to Approve Committee of Adjustment Meeting Minutes

10. Adjournment

**COMMITTEE OF ADJUSTMENT
MINOR VARIANCE
STAFF REPORTS**

Owner(s): Vishwas Raut, Manisha Raut, and Amol Raut
 Address: 1238 Bellview St. Burlington
 File No. **A-010/26**
 Ward: 1

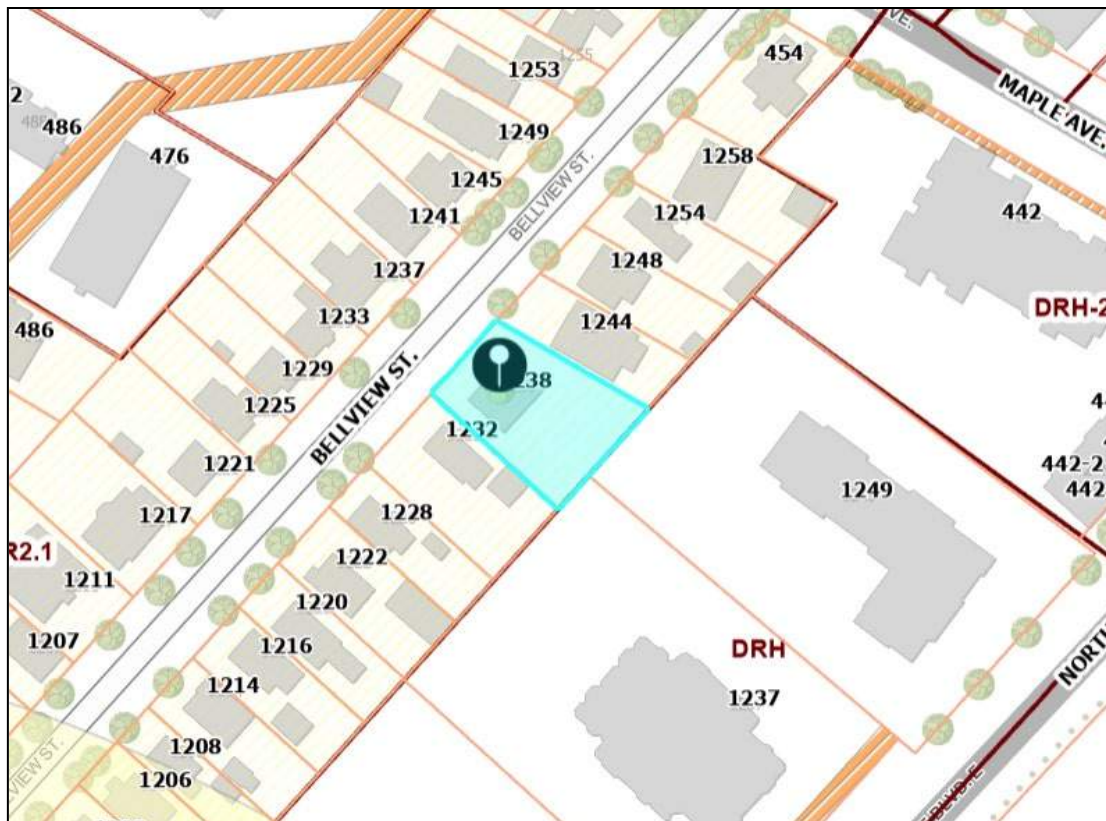

Staff Comments:

Committee of Adjustment

There are two previous minor variance applications on record for this property.
 There is one land division applications on record for this property.

File No. B007/2020 – Withdrawn

- To sever an existing oversized lot to create 2 smaller lots for residential use

File No. A083/2020 – Withdrawn

- Reduce lot width, lot size, front yard setback; increase floor area ratio and building height

File No. A084/2020 – Withdrawn

**COMMITTEE OF ADJUSTMENT
MINOR VARIANCE
STAFF REPORTS**

- Reduce lot width, lot size, front yard setback; increase building height; permit an accessory dwelling unit to have an entrance facing the street and a reduced landscaped area.

Date: February 10, 2025Prepared By: E. Shacklette**Zoning**

The subject property is zoned **R2.1**, Low Density Residential, under Zoning By-Law 2020, as amended, and is located in the designated area for lot coverage and floor area ratio. The **R2.1** zone requires, among other things, the following:

4.1 LOT WIDTH, AREA, YARDS

Table 2.4.1

Zone	Lot Width	Lot Area	Front Yard	Rear Yard	Side Yard	Street Side Yard
R2 ZONES						
R2.1	18 m	700 m ²	11 m	10 m	(a)	4.5 m

Footnotes to Table 2.4.1

(a) With attached garage or carport: 10% of actual lot width (24.871 m x 10% = 2.4871 m)

2.31 RESIDENTIAL BUILDING HEIGHT (Part 1)

A) R1, R2, R3, R4 Zones						
Flat Roof Dwellings		Building Height Maximum				
Detached	1 storey to	N/A	2 storey	N/A	N/A	
Semi-Detached	4.5 m		to 7 m			
Cluster						

Background:

A zoning clearance certificate was issued on November 7, 2023 for a new 2-storey detached dwelling with attached garage (Zoning Clearance Certificate #22-023721).

Proposal:

The applicant is proposing to revise the existing scope of work to alter the exterior finish from stucco to ACM panels, provide a new roof top access addition, and include a ramp access in side yard.

Variance required:

1. To permit a building height of 8.7 m instead of the maximum permitted 7.0 m for a proposed two storey dwelling with a flat roof and roof access.

**COMMITTEE OF ADJUSTMENT
MINOR VARIANCE
STAFF REPORTS**

Condition:

1. The applicant shall apply for a Pre-Building Approval application.

Notes:

1. The rooftop is not to be used as a terrace or rooftop amenity.
2. Variances have been identified based on the plans submitted for zoning review. If additional variances are identified when a Pre-Building Approval is made, they will be the responsibility of the applicant to obtain.
3. The zoning review is based on the portion of the site affected by the proposed development only.
4. The variances are being reviewed under Section 45(1) of the Planning Act.

Date: 28 April 2026Prepared By: Erin Ruby**Site Planning**

Site Characteristics	
Lot Frontage (m)	22.86 m
Lot Area (m²)	1,104.65 m ²
Existing Land Uses <i>(ex. buildings, structures, driveways, fences, etc...)</i>	Two storey dwelling (under construction)
Site Grading <i>(ex. Flat and level, significant grade differences)</i>	Generally flat and level
Notable Site Features	N/A
Surrounding Land Uses <i>(ex. Adjacent building relationships, natural features, notable adjacencies)</i>	Low-rise residential to the east, west and north and high-rise residential to the south
Nearest Major Intersection	Maple Ave and North Shore Blvd E
Neighbourhood Boundaries*	North: Maple Park East: Maple Ave South: North Shore Blvd E West: QEW
*Based on OP, 1997 residential neighbourhood definition	

Neighbourhood Characteristics:

- The built form to the east, west and north consists of one-storey, one-and-a-half-storey and two-storey detached dwellings.
- The streetscape is characterized by landscaped front yards, 6-7 front yard setbacks, mature trees and sidewalks abutting the curb of the road

**COMMITTEE OF ADJUSTMENT
MINOR VARIANCE
STAFF REPORTS**

- Although most houses on the street have sloped roofs, there are many different roof forms and houses vary in age, architectural style, cladding treatments, garage configuration and porch style
- Properties on the south side of Bellview Street back on to high density residential development that front onto North Shore Blvd East.
- Properties in the identified neighbourhood generally contain detached dwellings and are zoned LN3, LN4 and LN5. The neighbourhood also contains high rise apartments (DRH) and townhouses (DRM, RM1).

A site visit was conducted on May 14, 2026, and existing on-site conditions are summarized in site photos included in Attachment No. 1 (Site Photos). The dwelling is substantially completed and the roof access that requires the variance for increased height has been constructed. As is the case for applications where development requiring a variance has already been constructed, the application has been reviewed as if the work had not taken place.

The application requests a variance to permit a building height of 8.7 m instead of the maximum permitted 7.0 m. The maximum height is measured to the peak of a 4.5 m² raised roof structure that would allow access to the roof via a ladder placed on the second-floor interior stair landing (see photo in Attachment 1). The height of the house excluding the structure is 6.99 m, and 7.447 m if measured to the parapet. Under the Zoning Bylaw, parapets are excluded from the building height calculation.

Image of the front elevation of the dwelling.

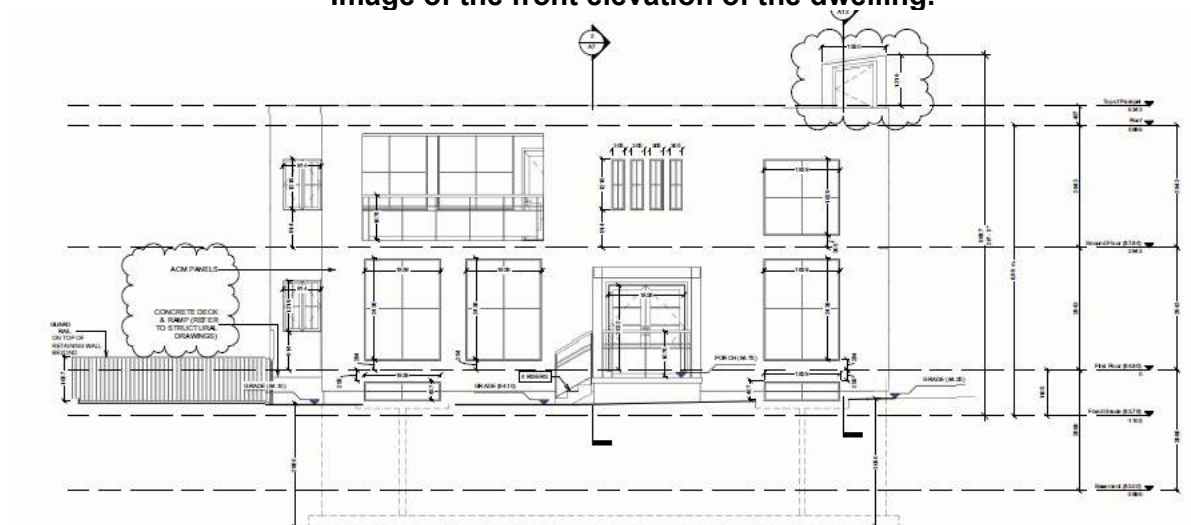

The roof complies with the requirements of the Zoning By-law, except for the roof access that is shown (clouded).

**COMMITTEE OF ADJUSTMENT
MINOR VARIANCE
STAFF REPORTS**

The access is approximately 4.5 m² in area, on a roof which has an approximate area of 265.4m². The access includes skylights however does not have any other windows. The access is located on the east side of the roof and is setback 5.1m from the front of the dwelling. The applicant has indicated to staff that the purpose of the access is for maintenance of the roof (removing leaves, checking waterproofing, monitoring for racoons etc.) and not for access to use the flat roof as an amenity area.

1) City of Burlington Official Plan:

Does the proposed minor variance(s) from the zoning by-law maintain the general intent and purpose of the Official Plan?

Yes

Regional Official Plan (2022):

The proposal meets the general intent and purpose of the Regional Official Plan, 2022 (ROP, 2022) for the following reasons:

- Section 76 of the ROP indicates that the range of permitted uses and the creation of new lots within the Urban Area will be in accordance with Local Official Plans and Zoning By-laws. Given that a two-storey dwelling is permitted by the City's Zoning By-law, staff are of the opinion that the proposal meets the general intent and purpose of the ROP.

Official Plan, 1997 & 2020

Parts of Burlington Official Plan, 2020 (BOP, 2020) are not in-force due to ongoing Ontario Land Tribunal Appeals, so applications are reviewed against a combination of in-force policies under BOP, 2020 and the older Burlington Official Plan 1997 (BOP, 1997).

The proposal/variance meets the general intent and purpose of the Official Plan for the following reasons:

- The proposal is consistent with the permitted uses under the property's 'Low-Rise Neighbourhoods I' land use designation according to Schedule 'C'/Schedule 'B' (Land Use - Urban Area/Comprehensive Land Use Plan- Urban Planning Area) of the BOP, 1997/BOP, 2020, as amended, which permits ground-oriented, low-density housing, and where compatible infill, small-scale additions, and renovations are encouraged.
- Whereas Section 8.3.2(1)(a)–(d) of the BOP, 2020 (Low-Rise Neighbourhoods I) directs that new development and additions shall be compatible with the surrounding context and maintain the predominant character of the neighbourhood with respect to height, massing, and setbacks, the proposal is consistent with these objectives in the following ways:

**COMMITTEE OF ADJUSTMENT
MINOR VARIANCE
STAFF REPORTS**

-
- Overall, the proposed detached dwelling complies with most Zoning Bylaw requirements including building setbacks, number of storeys and lot coverage.
 - The significant number of zoning conformities results in a built form that respects the planned character of the neighbourhood
 - Most of the building mass conforms to the maximum height and is consistent with the predominant massing of the neighbourhood characterized by detached dwellings that are one to two storeys in height.
 - Staff are of the opinion that the roof access will not have a noticeable impact on the massing of the dwelling given the small size of the roof access (4.5 m²).
- Whereas Section 8.3.3(1) e) (i) of the BOP, 2020 (Low-Rise Neighbourhoods I) directs that on lands designated Low-Rise Neighbourhoods I, in addition to the criteria contained in Subsection 12.1.7(2) of this Plan, the following criterion shall be considered when evaluating minor variance applications for increased height: the maximum building height should be comparable to the average height of the highest points of the rooflines of existing residential buildings on the immediately adjoining properties sharing lot lines with the lands under application. The proposal is consistent with these objectives in the following ways:
 - Based on available records (Zoning Clearances, Surveys), the following height data was obtained

Property	Height (m)	No. of Storeys	Roof Type
1244 Bellview Street	8.4 m	1.5	Peaked (Detached Dwelling)
1232 Bellview Street	7.3 m	1.5	Peaked (Detached Dwelling)
1249 North Shore Blvd E.	Linear height not available	11	Flat (Apartment)
1237 North Shore Blvd E.	Linear height not available	12	Flat (Apartment)
Average of known heights	7.8 m	6.5	

- 8.3.3(1) e) (i) specifically states the maximum building height should be comparable to the average height of the highest points of the rooflines of existing residential buildings on the immediately adjoining properties. In this case the residential buildings on the immediately adjoining properties includes apartment buildings fronting North Shore Blvd East. Staff are of the opinion that the objective of the policy is not to make height comparisons between vastly different building types (i.e. comparing the height of a detached dwelling to the height of an apartment). In the opinion of staff, the purpose of the policy is to compare the increases in height in the context of uses permitted in a Low-Rise Neighbourhood I

**COMMITTEE OF ADJUSTMENT
MINOR VARIANCE
STAFF REPORTS**

which includes detached dwellings, semi-detached dwellings and potentially other forms such as triplexes, fourplexes and townhouses up to a height of two storeys.

- While the height of the roof access (8.7 m) exceeds the average height of the two detached dwellings immediately adjoining the subject lands (7.8 m), the height is lower than the maximum building height of a peaked roof dwelling (10 m). For this reason, staff believe that the increased height would not appear out of place in the context of a streetscape which permits a maximum height of 10 m. A photo of the subject lands in context with the dwellings on immediately adjoining properties is below, demonstrating that the notwithstanding the roof access, the roofline of the subject lands is in general alignment with the rooflines of neighbouring dwellings:



- Whereas compatible is defined as “Development or re-development that is capable of co-existing in harmony with, and that will not have an undue physical (including form) or functional adverse impact on, existing or proposed development in the area or pose an unacceptable risk to environmental and/or human health”, which is evaluated in accordance with measurable/objective standards, the planner notes the following:
 - The proposal will not result in undue physical impacts, as the purpose of the roof access is to allow a means for maintaining the roof and not for access to an amenity area thereby avoiding impacts associated with overlook, privacy, or amenity areas.
 - The addition does not introduce any new functional impacts, including noise, drainage, or servicing concerns, and remains consistent with the established residential use of the area.

2) City of Burlington Zoning By-law 2020:

Does the proposed minor variance(s) from the zoning by-law maintain the general intent and purpose of the Zoning By-law?

Yes

**COMMITTEE OF ADJUSTMENT
MINOR VARIANCE
STAFF REPORTS**

The general intent and purpose of the maximum building height provision is to control building scale and massing, maintain consistent streetscapes and minimize visual impacts on surrounding properties. Flat roofs are subject to lower height limits because they maximize interior space at the top of the building and can appear more bulky or box-like compared to sloped roofs, which are typically less imposing. This distinction in maximum height helps ensure balanced massing regardless of roof style. The proposed minor variance is consistent with this intent for the following reasons:

- The proposed height remains within the range of building heights in the surrounding neighbourhood where peaked roofs are permitted to be 10 m in height, therefore maintaining a consistent streetscape.
- The requested increase in height is for a small (4.5 m²) area and therefore has little impact on the massing of the dwelling which would continue to be perceived as a typical two-storey flat roof dwelling.

3) Desirability:

Is the proposed minor variance from the zoning by-law desirable for the appropriate development or use of the land, building or structure?

Yes

The proposed variance is desirable for the appropriate development of the land because:

- The development is in keeping with the surrounding low-rise neighbourhood
- Overall, the variance allows for the efficient and appropriate use of the property (i.e. for roof maintenance to take place) while maintaining compatibility with the surrounding neighbourhood and the general intent of the Zoning By-law.

4) Minor in Nature:

Is the proposed minor variance(s) from the zoning by-law considered minor in nature?

Yes

The proposed variance is considered minor in nature for the following reasons:

- The requested increase in height is for a small percentage of the area of the roof and will therefore not alter the massing of the dwelling significantly.
- The proposed height increase will result in a perceived building height that appears as a typical two-storey dwelling when viewed from the street and neighbouring properties.
- The variance would not result in undue massing, shadowing, privacy, or functional impacts, and therefore is minor in overall effect.

**COMMITTEE OF ADJUSTMENT
MINOR VARIANCE
STAFF REPORTS**

Cumulative Effects of Multiple Variances and Other Planning Matters:

Not Applicable.

Recommendation:

Staff has reviewed the proposed variance in accordance with the Planning Act, the policies of the Official Plan and the requirements of the Zoning By-law and has no objection.

Date: May 21, 2026

Prepared By: Melissa Dalrymple, MCIP, RPP

Report Schedules & Attachments:

Attachment No. 1 (Site Photos)



View of subject lands from Bellview Street.



View of subject lands and constructed roof access from Bellview Street.

**COMMITTEE OF ADJUSTMENT
MINOR VARIANCE
STAFF REPORTS**

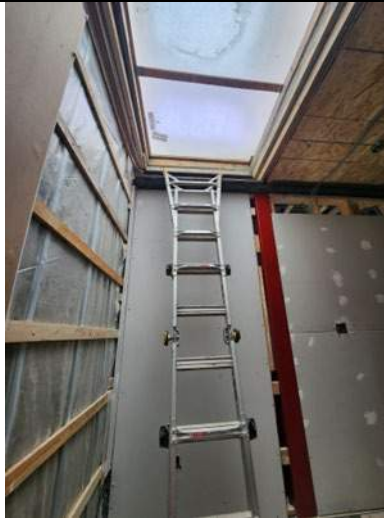

View of roof access from inside the dwelling.



Subject lands in context with the dwellings on immediately adjoining properties.



View of the dwellings on the north side of Bellview Street across from subject lands.

**COMMITTEE OF ADJUSTMENT
MINOR VARIANCE
STAFF REPORTS**



View of 1249 North Shore Blvd E.



View of 1237 North Shore Blvd E.

Technical Reviewer Comments:

Development Engineering

Development Engineering has reviewed the proposed minor variances and has no objection to the variance(s) requested. Revisions to the plans may be required through the Grading and Drainage Clearance Certificate process.

Date: May 11, 2026

Prepared By: R. Bardaloo

Forestry

Forestry has no objection to the proposed minor variance(s) and provides the following advisory note(s) to the applicant:

1. A tree permit will be required for any and all work around regulated trees in accordance with the City's Tree By-laws.
2. Revisions to the report and/or plans may be required through the tree permit process.

Date: May 8, 2026

Prepared By: R. Shaw-Lukavsky

Building

Building comments unavailable at time of publication and will be forthcoming at a later date.

**COMMITTEE OF ADJUSTMENT
MINOR VARIANCE
STAFF REPORTS**

Transportation Planning

Deemed Road Width Analysis

Bellview Street is under the authority of the City of Burlington and the deemed right-of-way width is 20 metres. The right of-way adjacent to the subject site is approximately 20 metres therefore no additional lands are required.

Date: February 11, 2026 Prepared By: Thalia Thompson

Transportation Planning have no comments because the application has no impact on parking, or the adjacent street. The driveway location and width are acceptable for the land use and sight lines.

Date: May 14, 2026 Prepared By: D. Napoli

Finance

Notice regarding Development Charges:

The owner, its successors and assigns, are hereby notified that City Development Charges may be payable in accordance with the applicable By-law 72-2004, as may be amended, upon issuance of a building permit, at the rate in effect on the date issued. For further information, the owner is advised to contact the City Building Department (905) 335-7731.

Tax

All property taxes including penalty and interest must be paid. This includes all outstanding balances plus current year taxes that have been billed but are not yet due. Local improvements must be commuted.

Date: April 30, 2026 Prepared By: L. Bray

Agency Comments:

Halton Region

Regional Contaminated Sites Database:

In order to maintain the Region's Contaminated Sites Database, Regional staff request final copies of all environmental reports (if applicable) including: Geotechnical Studies, Hydrogeological Studies, Phase One and/or Two Environmental Site Assessments, Remediation Reports, Risk Assessments, Record of Site Condition (RSC), and/or Certificate of Property Use (CPU).

**COMMITTEE OF ADJUSTMENT
MINOR VARIANCE
STAFF REPORTS**

Regional Staff have reviewed the Minor Variance application proposing to revise the existing scope of work to alter the exterior finish from stucco to ACM panels, provide a new roof top access addition, and include a ramp access in side yard. Variance is requested to the maximum permitted building height.

- Due to Provincial legislation, as of July 1, 2024, the Halton Region's role in land use planning and development matters has changed. The Region is no longer responsible for the Regional Official Plan – as this has become the responsibility of Halton's four local municipalities. As a result of this change, a Memorandum of Understanding (MOU) between the Halton municipalities and Conservation Authorities has been signed that identifies the local municipality as the primary authority on matters of land use planning and development. The MOU also defines the continued scope of interests for the Region and the Conservation Authorities in these matters.
- Regional Staff have no objections to the Minor Variance application.

Date: May 11, 2026

Prepared By: Navjot Kaur

Burlington Hydro

Comments not received by the time this report was published.

The applicant/owner is responsible for connecting with Burlington Hydro regarding their proposed development.

NOTICE OF PUBLIC HEARING

Vishwas Raut, Manisha Raut and Amol Raut of 1238 Bellview St, Burlington, have applied to the Committee of Adjustment for a Minor Variance to the requirements of Zoning By-law 2020, as amended. The property in question is **1238 Bellview St. Burlington** (see map).

The applicant is proposing to revise the existing scope of work to alter the exterior finish from stucco to ACM panels, provide a new roof top access addition, and include a ramp access in side yard. This proposal results in the following variance:

1. To permit a building height of 8.7 m instead of the maximum permitted 7.0 m for a proposed two-storey dwelling with a flat roof and roof access.

You have received this notice as stipulated by the *Planning Act* because your property is within 60 metres of the property noted above. The application materials are available on request by contacting Committee of Adjustment staff by one of the methods listed above. A copy of the Agenda, containing staff reports and drawings, can be viewed online under the Meeting Agenda tab at **Burlington.ca/coa** on or after **May 19, 2026**.

Committee of Adjustment Hearings will be hybrid-conducted in person and virtually. All members of the public, applicants and their agents will now have the option to participate in the public meeting process in person at City Hall in Council Chambers, or remotely via Zoom Webinar Video Conferencing Technology. The Committee of Adjustment will meet to consider the above application under Section 45 of the *Planning Act*, 1990, as amended on:

WEDNESDAY JUNE 3, 2026,

This application is scheduled to be heard at or after 5:30 pm.

How to participate if I have comments or concerns?

Written Submissions

Members of the public who would like to participate in a Committee of Adjustment meeting are able to send written comments regarding the application by e-mail to committeeofadjustment@burlington.ca with the subject line to read "Comments_Your Name_File No._Address of the Property".

Alternatively, written comments can be sent by regular mail addressed to the Secretary-Treasurer. Include your name, address, application number and address of the property for which you are providing comments.

To allow all Committee of Adjustment members the opportunity to review and consider your comments, please provide your written submissions to be received no later than noon the day before the hearing date.

Oral Submissions

Members of the public are also able to provide oral comments regarding Committee of Adjustment Hearing items by participating virtually through Zoom via computer or phone, or by attending the Hearing in-person. Participation virtually requires pre-registration in advance. Please contact staff for instructions if you wish to make a presentation containing visual materials.

1. Virtual Oral Submissions

To register as a delegate, please contact the Secretary-Treasurer no later than 12:00 p.m. (noon) the day before the hearing date. The following information is required to register; Committee of Adjustment file number, hearing date, name, and mailing address of each person wishing to speak, if participation will be by phone or video. All requests to delegate must contain a copy of your intended remarks which will be circulated to all members of Committee in advance.

2. In person Oral Submissions

Interested members of the public, agents, and owners who wish to participate in person may attend Council Chambers on the date and time listed on the Notice of Public Hearing. Please note that you will be required to provide your name and address for the record. It is advised that you arrive no less than 10 minutes before the time of the Public Hearing as noted on the Notice of Public Hearing.

Attend or View the Committee of Adjustment Hearing:

If you do not wish to participate, but would like to follow along, the hearing will be held in person at City Hall in Council Chambers and live through a Zoom Webinar. Instructions, links and phone numbers for joining the meeting will be posted on the Committee of Adjustment webpage the day prior to the scheduled meeting. The link will be active at **5:00 p.m.**

If you wish to be notified of the decision of the Committee of Adjustment in respect to this application, you must submit a written request to the Secretary-Treasurer. This will also entitle you to be advised of a possible Ontario Land Tribunal Hearing. In accordance with the Planning Act, the Committee of Adjustment decision may be appealed to the Ontario Land Tribunal by the owner, the Minister of Municipal Affairs and Housing, a specified person or public body that has an interest in the matter.

The applicant is advised that it is **mandatory** that either the applicant or an authorized agent of the applicant must be present at the hearing either in person or virtual.

For more information about this matter, contact Catherine Susidko-Petriczko at committeeofadjustment@burlington.ca

Yours truly,

Catherine Susidko-Petriczko
Secretary-Treasurer
Committee of Adjustment

Personal information including comments and public feedback, is collected under the legal authority of the Planning Act, R.S.O. 1990, Chapter c. P.13, as amended, and the Municipal Freedom of Information and Protection of Privacy Act, R.S.O. 1990, as amended, which will be used to process the application and in the decision making process and becomes the property of the City of Burlington, and is considered to be a public record and will be disclosed to any individual (including being posted on the internet) upon request. Questions about this collection should be directed to the Secretary-Treasurer, Burlington Committee of Adjustment, Community Planning Department, 426 Brant Street, P.O. Box 5013, Burlington, Ontario; L7R 3Z6 (905) 335-7629.

Key Map

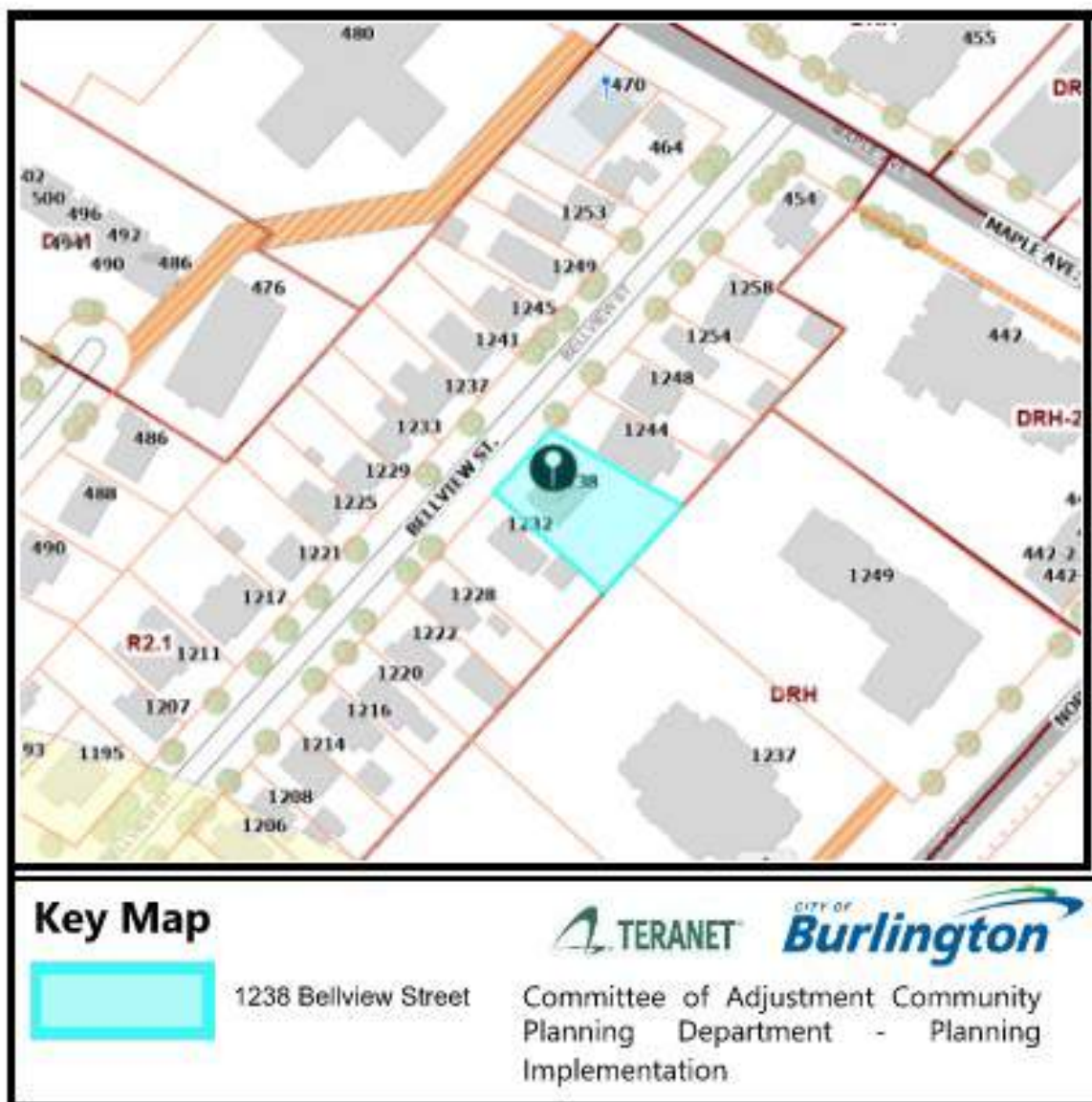

PLANNING ACT, R.S.O. 1990, C.P. 13
APPLICATION FOR MINOR VARIANCE OR FOR PERMISSION

THE UNDERSIGNED HEREBY APPLIES TO THE COMMITTEE OF ADJUSTMENT FOR THE CITY OF BURLINGTON UNDER SECTION 45 OF THE PLANNING ACT, R.S.O. 1990, C.P.13, AS DESCRIBED IN THIS APPLICATION, FROM BY-LAW NO. 2020. (AS AMENDED)

Application made under:

Section 45 (1) of the Planning Act

Section 45 (2) of the Planning Act

Discussed the application with a City Zoning Examiner and Development Planner Y or N

Name of Planner: Kendra Cockhill

Name of Zoning Examiner: Nataliya Yatsenko

PROPERTY INFORMATION

Municipal Address(es) of property:

1238 Bellview Street

Legal Description of property:

Official Plan Designation: Residential Current Zoning Designation Residential

OWNER(S) INFORMATION:

Legal Name (as it appears on the title for the property):

Raut Vishwas ~~MAVISH~~ RAUT AMOZ RAUT.

Mailing Address: 1238 Bellview Street City: Burlington

Postal Code: L7S1C7 Home Phone: _____ Mobile Phone: _____

Work Phone: _____ E-Mail: _____

AGENT INFORMATION (if applicable): (This person will be the primary point of contact if provided)

Name: SHASHANK CHITALE

Business Address: 1109 BRITANIA ROAD City: MISSISSAUGA

Postal Code: L4W 3X1 Home Phone: _____ Mobile Phone: _____

Work Phone: _____ E-Mail: _____

PROPOSED DEVELOPMENT Please outline in detail your proposed development and list each variance you are requesting, as well as the Zoning By-law Requirements. Attach a separate sheet if required.

Proposed residence is under construction. Owner wishes to have access to the flat roof through a 9' X 5', 4' High structure (2.85mt X 1.55mt, 1.2mt High)

Variance(s) Requested	Zoning Bylaw Requirement
Building height 8.67 mts	7.00 mts

In your own words, please explain why you are unable to comply with the provisions of the Zoning By-law and how the minor variance(s) meet the four (4) tests under the Planning Act:

- Why is the variance(s) minor in nature? _____
This structure is at one side of the house and only 4' (1.22 mt) above the parapet. There is no stairs provided. Owner shall use a ladder to climb
- Why are the variance(s) desirable for the appropriate use of the land? _____
There is a need to access the flat roof from within the house to clear the leaves and maintain and monitor the roof for maintenance
- Do the variance(s) meet the intent and purpose of the Official Plan? _____
This roof access structure is intended to maintain the integrity of the structure by providing access to the flat roof
- Do the variance(s) meet the intent and purpose of the Zoning By-law? _____
The building height is more than the zoning by-law but the intention is very reasonable

PROPERTY DETAILS (please complete all fields):

Date property purchased: <u>FEB 16, 2021</u> 02 mmm/dd/yyyy	Date property first built on: <u>APRIL, 2025</u> mmm/dd/yyyy	Date of proposed construction: _____ mmm/dd/yyyy
---	---	---

Existing Use of the Subject Property (check one): Detached Dwelling <input checked="" type="checkbox"/> Semi-Detached Dwelling <input type="checkbox"/> Townhouse Dwelling <input type="checkbox"/> Street Townhouse Dwelling <input type="checkbox"/> Stacked Townhouse Dwelling <input type="checkbox"/> Apartment <input type="checkbox"/> Mixed Use <input type="checkbox"/> Hi Rise <input type="checkbox"/> Commercial <input type="checkbox"/> Industrial <input type="checkbox"/> Vacant <input type="checkbox"/> Other <input type="checkbox"/>	Length of time the existing uses of the subject property have continued: more than 60 years
	Proposed Use of the Land: single family residence

Existing Uses of Abutting Properties (check all that apply)

Residential Commercial Industrial Multi-Residential Vacant Hydro right-of-way
 Railway right-of-way Provincial Highway Park Other
 Conservation Halton Lands: Lake Ontario Creek Storm Water Management Pond/Channel
 Ravine

Additional Information

Is liquor sold on site? Y or N

Is the property on the Municipal Cultural Heritage Register for the City of Burlington? Y N
 Unknown

Type of Access to the Subject Lands

Provincial Highway <input type="checkbox"/>	Municipal Road <input checked="" type="checkbox"/>	Private Road <input type="checkbox"/>	Water <input type="checkbox"/>	Other(specify) <input type="checkbox"/>
---	--	---------------------------------------	--------------------------------	---

Municipal Services Provided

Water <input checked="" type="checkbox"/>	If not available, by what means is it provided: _____
Sanitary Sewers <input checked="" type="checkbox"/>	If not available, by what means is it provided: _____
Storm Sewers <input checked="" type="checkbox"/>	If not available, by what means is it provided: _____

IS THE SUBJECT LAND(S) THE SUBJECT OF ANY OF THE FOLLOWING DEVELOPMENT APPLICATIONS:

Official Plan Amendment Zoning By-law Amendment Building Permit
 Site Development Plan Plan of Subdivision Previous Minor Variance Consent

FOR RESIDENTIAL DETACHED OR SEMI-DETACHED DWELLINGS

Dimensions of Property			Street Width (see first page of application for how to obtain)			Lot Coverage	Corner Lot? Y <input type="checkbox"/> N <input checked="" type="checkbox"/>
Frontage	Depth	Area	Actual	Deemed	Required		
22.86	40.39	1,104.65	13.66			274.07 sqm (23%)	

Particulars of all buildings and structures on or proposed for the subject lands

(attach additional page if required)

EXISTING (Dwelling/Building)		PROPOSED (Dwelling/Building/Addition)	
Ground Floor Area (incl. attached garage)	M ²	Ground Floor Area (incl. attached garage) 254.57	M ²
Gross Floor Area:	M ²	Gross Floor Area: 492.95	M ²
Number of Storeys:		Number of Storeys: 2	
Width:	M	Width: 14.89	M
Length:	M	Length: 17.82	M
Height:	M	Height: 8.67	M
Garage/Car Port		Garage/Car Port	
Detached?	Y <input type="checkbox"/> N <input type="checkbox"/>	Detached?	Y <input type="checkbox"/> N <input checked="" type="checkbox"/>
Gross Floor Area:	M ²	Gross Floor Area:	M ²
Width:	M	Width:	M
Length:	M	Length:	M
Height:	M	Height:	M
Accessory Structures (Shed, Gazebo, etc)		Accessory Structures	
Gross Floor Area:	M ²	Gross Floor Area:	M ²
Width:	M	Width:	M
Length:	M	Length:	M
Height:	M	Height:	M
Other (pool, additional sheds, decks, driveways, etc.)		Other	
Gross Floor Area:	M ²	Gross Floor Area:	M ²
Width:	M	Width:	M
Length:	M	Length:	M
Height:	M	Height:	M
LOCATION of all existing and proposed buildings and structures			
EXISTING		PROPOSED	
Front:	M	Front:	M
Rear:	M	Rear:	M
Side/Street Side:	M	Side/Street Side:	M
Side/Other Side:	M	Side/Other Side:	M

EXEMPTION FROM NEW SURVEY REQUIREMENT

Minor additions to an existing dwelling or for a proposed accessory building or structure (i.e., deck, driveway, pergola, shed), may be exempt from having to provide a new survey. Please refer to Page 3 of this application package for more details. Minor Variances with concurrent Consent applications require a new survey.

Applicant/Owner:

VISHWAS RAUT

Property Address:

1238 BELLVIEW ST.

1. I, MANISHA RAUT AMOL RAUT In my capacity as OWNERS do attest to the following:
VISHWAS RAUT
Print Name (Owner or agent)

Please complete Section A, B, or C

A. The OLS survey/sketch of survey dated _____ mmm/dd/yyyy
has been revised by: _____
(Person or Company Name)
OR

B. The site plan, architect's plan or engineer's plan dated _____ mmm/dd/yyyy
has been revised by: _____
(Person or Company Name)
OR

C. The sketch or plot plan** dated _____ mmm/dd/yyyy
**Accepted for applications involving variances for Uses only.
was prepared by: _____
(Person or Company Name)

2. All structures, measurements, setbacks and boundaries of the property are shown accurately as of: _____ mmm/dd/yyyy

3. The material submitted shows all measurements in metric, as calculated/converted by: _____
(Person or Company Name)

4. Should the need arise during application processing for an new OLS survey, the applicant/agent agree to provide the survey as required by Committee or city staff in order to receive a decision on the application.

V Raut
Signature of Owner/Applicant

FEB 02/2026
Date (mmm/dd/yyyy)

POSTING OF ADVISORY SIGN

This will confirm the requirement of the Committee of Adjustment for a sign to be posted by all applicants or agents on each property under application.

A sign will be made available to you after completion of the zoning review of your application(s) and you are directed to post each sign in a prominent location that will enable the public to observe the sign.

The location of each sign will depend on the lot and location of structures on it, however, the sign should be placed so as to be legible from the roadway in order that the public can see the sign and make note of the telephone number should they wish to make inquiries. In most cases, please post the sign on a stake as you would a real estate sign. For commercial or industrial buildings it may be appropriate to post the sign on the front wall of the building at its entrance. Please contact the undersigned if you have any queries on the sign location.

DO NOT POST THE SIGN INSIDE THE BUILDING BY A WINDOW. The sign must be outdoors by the roadway in order to be visible and readable.

Each sign must remain posted beginning 10 days prior to the hearing, until the day following the hearing. Please fill in the form below indicating your agreement to post the sign(s) as required. This form must be submitted with the application so that it may be placed on file as evidence that you have met the committee's requirements. Failure to post the sign as required will result in deferral of the application.

I UNDERSTAND THAT EACH SIGN MUST BE POSTED AT LEAST 10 DAYS BEFORE THE HEARING, AND WILL REMAIN POSTED AND BE REPLACED, IF NECESSARY, UNTIL THE DAY FOLLOWING THE HEARING.

Owner Name	<u>VISHWAS RAUT</u>	Property Address	<u>1238 BELLVIEW ST.</u>
	<u><i>VRaut</i></u>		<u>FEB, 02, 2026</u>
	Signature of Owner/Applicant		Date (mmm/dd/yyyy)

OWNERS AUTHORIZATION

If using an agent, the owner must also complete the following form:

I, VISHWAS RAUT being the registered owner of the subject lands, hereby
(print name)

Authorize SHASHANK CHITALE to prepare, submit and act on my behalf with respect to this
(print agent name)

application for a Minor Variance.

V Raut
Signature of Owner

FEB 02, 2026
Date (mmm/dd/yyyy)

Notice of collection of personal information

Personal information contained on this form is collected under the authority of the Planning Act, RSO 1990, c. P.13, to process applications and make decisions. Applications made under the Planning Act, are considered part of the public record and shall be made available to the public. Questions about this collection can be directed to the Manager of Development Planning, City of Burlington, 426 Brant Street, Burlington, Ontario, L7R 3Z6, 905-335-7600.

The applicant acknowledges that an application, all supporting information and materials, including studies and drawings, submitted under the Planning Act, pursuant to s. 1.0.1 of the Planning Act, RSO 1990, c.P.13, as amended, shall be made available to the public.

AFFIDAVIT

*Please fill out at time of submission of application

I have the authority to bind the Corporation (check if applicable) Signature of Applicant or Authorized

Agent: VISHWAS RAUT
I, VISHWAS RAUT of the BUR CITY of BURLINGTON in the REGION
(print name) (Region/City/County) (City/Town/Township)

of HALTON solemnly declare that all the statements contained in this application are true and I make this solemn declaration conscientiously believing it to be true and knowing it is of the same force and effect as if made under oath and by virtue of the Canada Evidence Act.

Declared before me at the Region of Halton in the City of Burlington
(Region/City/County) (City/Town/Township)

this 9th day of February 2026.

Aleksandra Narcyza Hutchison, a
Commissioner, etc., Province of
Ontario, for The Corporation of the
City of Burlington.
Expires October 25, 2027.

[Signature]
Signature of Commissioner, etc.

[Signature]
Signature of Applicant or Authorized Agent

PERMISSION TO ENTER

IMPORTANT This MUST be completed for all applications and signed by the OWNER.

Municipal Address of Subject Lands: 1238 BELLVIEW ST. BURLINGTON

I hereby authorize the Committee of Adjustment members, City of Burlington and Region of Halton staff to enter onto the above-noted property for the limited purposes of evaluating the merits of this application.

[Signature]
Signature of Owner

VISHWAS RAUT
Print Name

BELLVIEW STREET (by Registered Plan 109)

P.I.N. 07084-0407

Copyright Act Applies to Use and Production

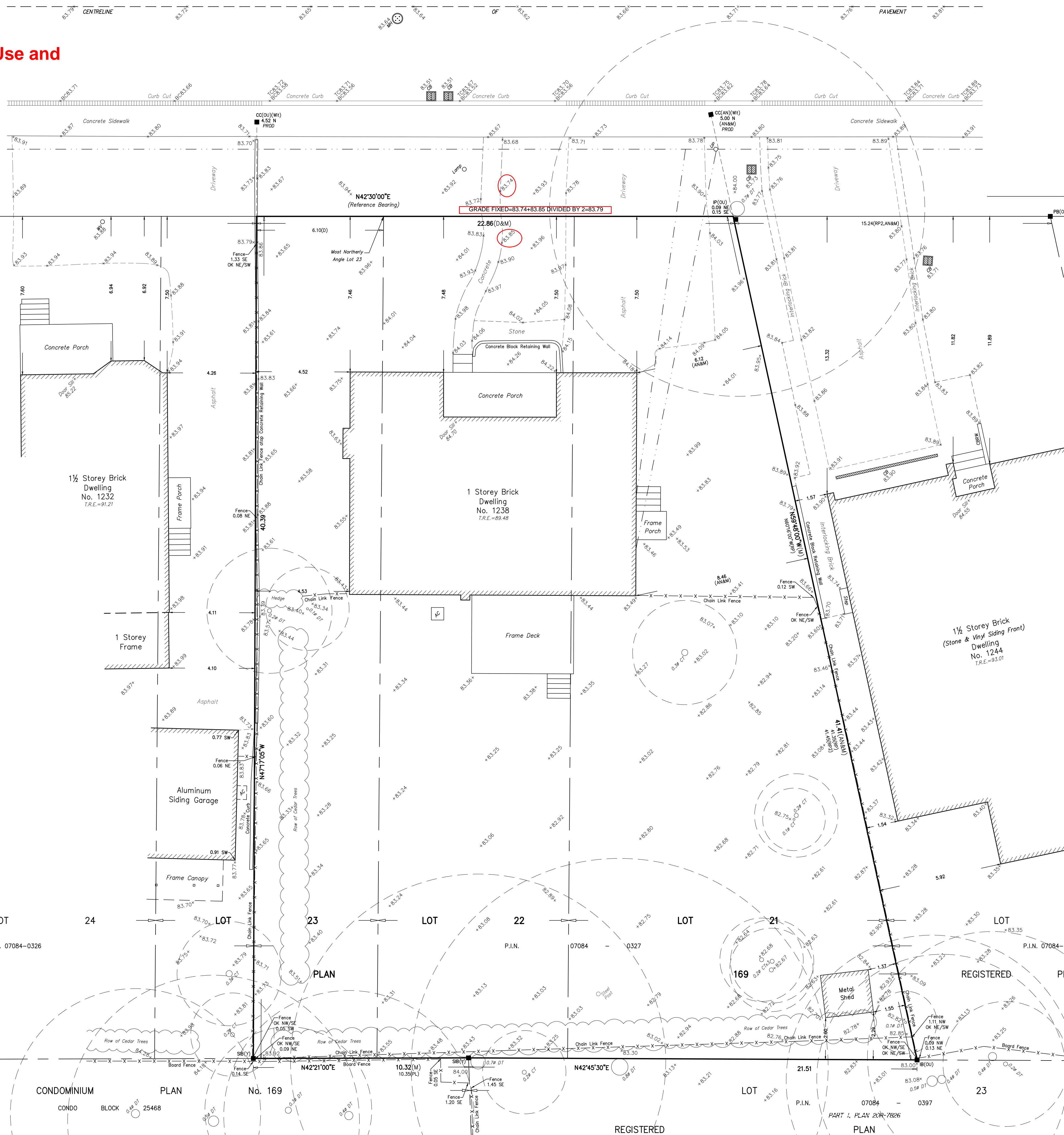
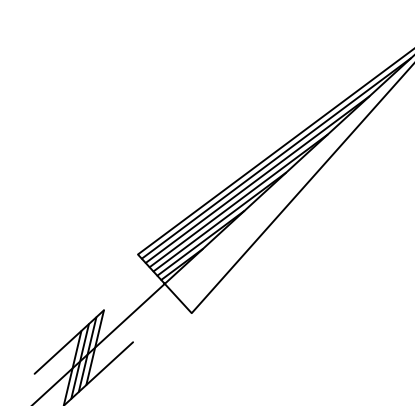

SURVEYOR'S REAL PROPERTY REPORT - PART 1
 PLAN OF SURVEY OF
LOTS 21 and 22
 and
Part of LOT 23
REGISTERED PLAN 169
CITY of BURLINGTON
 Regional Municipality of Halton
 SCALE 1 : 100
 GTA SURVEYING INC.
 © COPYRIGHT 2022

METRIC
 DISTANCES SHOWN ON THIS PLAN ARE IN METRES AND CAN BE CONVERTED TO FEET BY DIVIDING BY 0.3048

BEARING NOTE
 BEARINGS ARE ASTROMETRIC AND ARE REFERRED TO THE SOUTHEASTERLY LIMIT OF BELLVIEW STREET, HAVING A BEARING OF N42°30'00"E ACCORDING TO REGISTERED PLAN 169

ELEVATION NOTE
 ELEVATIONS ARE GEODETIC AND ARE REFERRED TO THE CITY OF BURLINGTON BENCHMARK No. 42, HAVING A PUBLISHED ELEVATION OF 82.015 METRES

LEGEND

■	DENOTES SURVEY MONUMENT FOUND
RP	REGISTERED PLAN 169
RP2	REGISTERED PLAN 109
N,S,E,W	NORTH,SOUTH,EAST,WEST
M	MEASURED
CC	CUT CROSS
IB	IRON BAR
SIB	STANDARD IRON BAR
PB	PLASTIC BAR
OU	ORIGIN UNKNOWN
PROD	ON PRODUCTION
WT	WITNESS
D	INSTRUMENT No. 129022
PL2	HALTON CONDOMINIUM PLAN No. 169
AN	PLAN BY ASHENHURST NOUWENS & ASSOCIATES INC., O.L.S., DATED MAY 6, 2019
Y	YATES & YATES LTD., O.L.S.
P.I.N.	PROPERTY IDENTIFIER NUMBER
---	OVERHEAD WIRES & UTILITY POLE
TC	TOP OF CURB
BC	BOTTOM OF CURB
AC	AIR CONDITIONER
CS	CATCH BASIN
CBRW	CONCRETE BLOCK RETAINING WALL
CT	CONIFEROUS TREE
DT	DECIDUOUS TREE
MH	MANHOLE
UP	UTILITY POLE
WV	WATER VALVE
T.R.E.	TOP OF ROOF ELEVATION

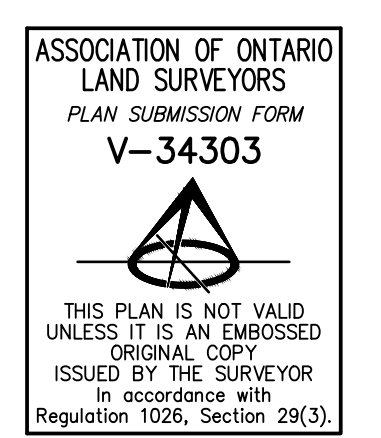

SURVEYOR'S CERTIFICATE
 I CERTIFY THAT:
 1. THIS SURVEY AND PLAN ARE CORRECT AND IN ACCORDANCE WITH THE SURVEYS ACT, THE SURVEYORS ACT, AND THE REGULATIONS MADE UNDER THEM.
 2. THE SURVEY WAS COMPLETED ON THE 25th DAY OF AUGUST, 2022.

SEPTEMBER 27, 2022
 DATE
 JACK WALCZAK
 ONTARIO LAND SURVEYOR

THIS PLAN WAS PREPARED FOR ANTRIX ARCHITECTS INC.
PART 2 - SURVEY REPORT
 1) PLEASE NOTE LOCATION OF FENCES AND OVERHEAD WIRES
 2) REGISTERED EASEMENTS AND/OR RIGHTS-OF-WAY: NONE
 3) THIS PLAN DOES NOT CERTIFY COMPLIANCE WITH ZONING BY-LAWS

GTA
 Greater Toronto Acres
 SURVEYING INC.
 7003 Steeles Ave. West, Unit 12, Toronto ON M9W 0A2
 Tel: (416) 679-0572
 E-MAIL: jw@gtasurveying.ca

DRAWN: M.C. CHECKED: P.W. PROJECT 22224

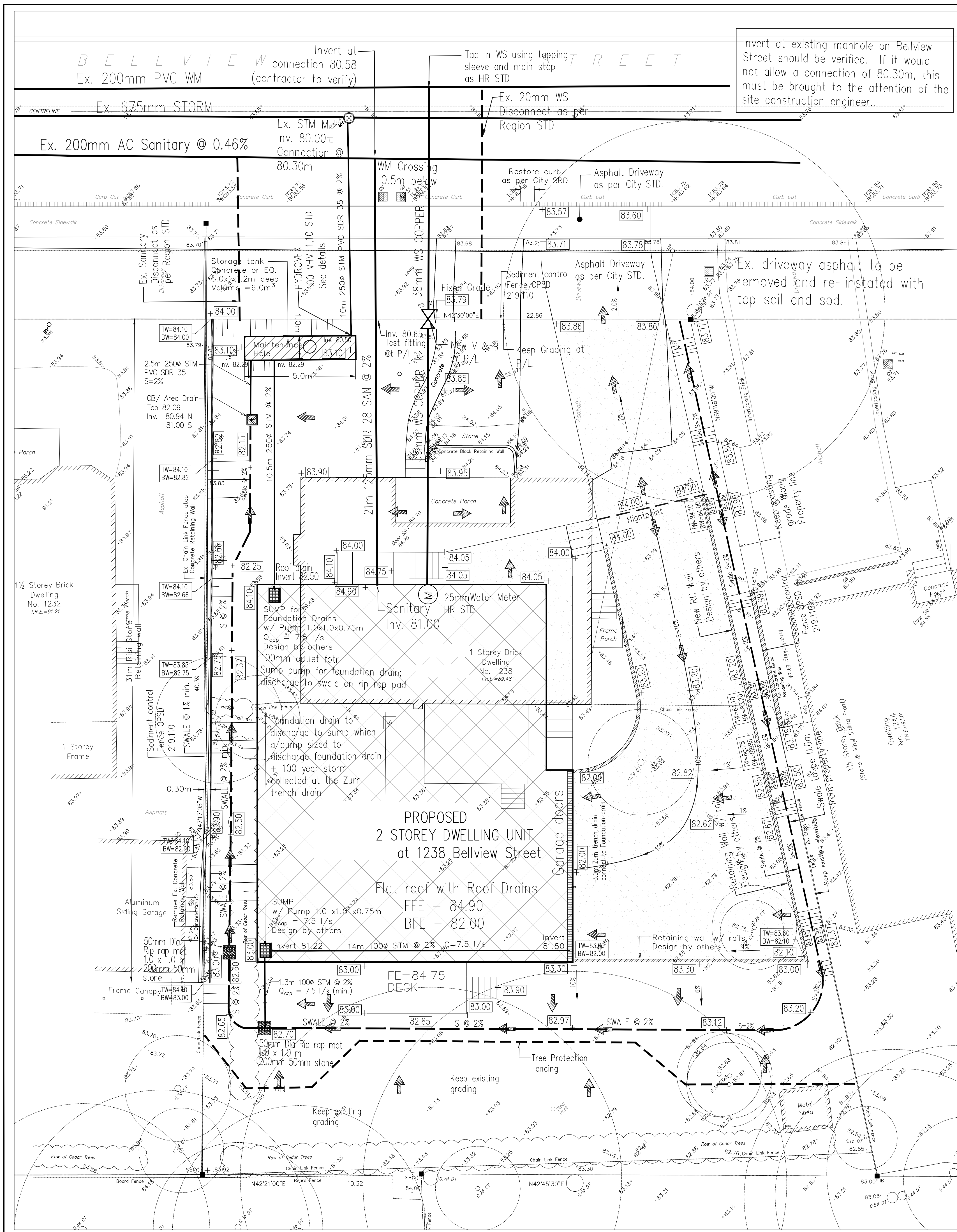

Notes for sump pump

Sump pump/ downpouts to be managed within property boundaries and not have any adverse effect on abutting or city owned lands and infrastructure including ditches

Service connection trench within the traveled portion of the road allowance shall be backfilled in accordance with the requirements of the road Occupancy/ Access Permit Application

All damaged or disturbed areas within the municipal right-of-way are to be reinstated at the applicant's expense.

All landscaping and grading within close proximity to the proposed access points is to be designed to ensure that adequate sight distances are available for all approaching and exiting motorists and pedestrians.

The portion of the driveway within the municipal boulevard is to be paved by the applicant.

WATERMAIN

1. The Regional Municipality of Halton materials, specifications and construction methods shall be part of the design.
2. All water service shall have at least 1.70m minimum cover, and a minimum horizontal spacing of 1.2m from all other utilities.
3. For watermain crossing over utilities a minimum of 0.3m vertical clearance shall be provided. If the watermain will be under utilities, the minimum clearance shall be 0.5m.
4. All proposed water piping must be isolated from existing lines to allow independent pressure testing and chlorination.
5. Location of all existing utilities in the field to be established by the contractor.
6. The 38mm watermain shall be Copper "K".
7. All live tapping of Region watermain shall be done in accordance with the Region of Halton.
8. Provision for flushing watermain prior to testing must be provided with at least a 50mm outlet. Copper watermain are to have flushing points at the end, the same size as the watermain.
9. Thrust blocks for watermain to be installed as per regional standards.
10. Valve and boxes shall be the types and sizes approved by the Region.
11. Bedding for watermain shall be per Regional standard.
12. The Region shall undertake the necessary water testing (pressure test, flushing, and chlorination). Contractor may proceed with his own pressure
13. Test and flush prior to Region's testing.
14. The need for tracer wires for locating purposes shall be determined by the Region of Halton inspector. If required, it must be done in accordance with the standards.

Copyright Act Applies to Use and Production

Notes

The proposed development of the subject site may negatively impact the root zones of nearby trees on adjacent property and ultimately damage the trees. The owner should take all reasonable steps to minimize disturbance to the adjacent trees root zones that are within the subject site

Hoarding must be installed on site as required by the Arborist, and must be inspected prior to final site plan approval.

Copyright Act Applies to Use and Production

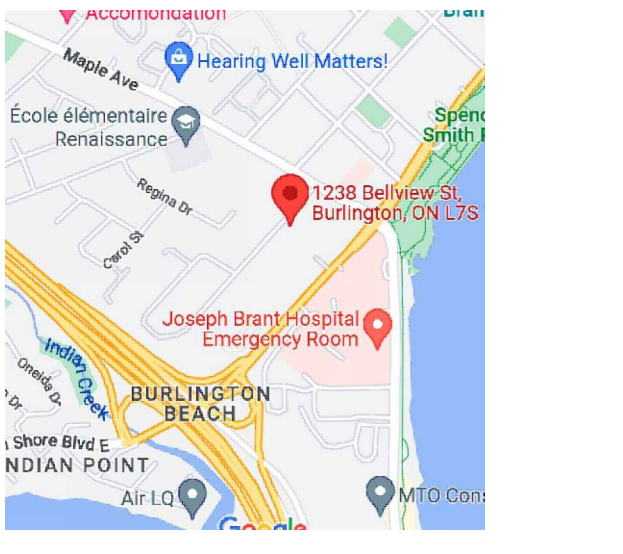
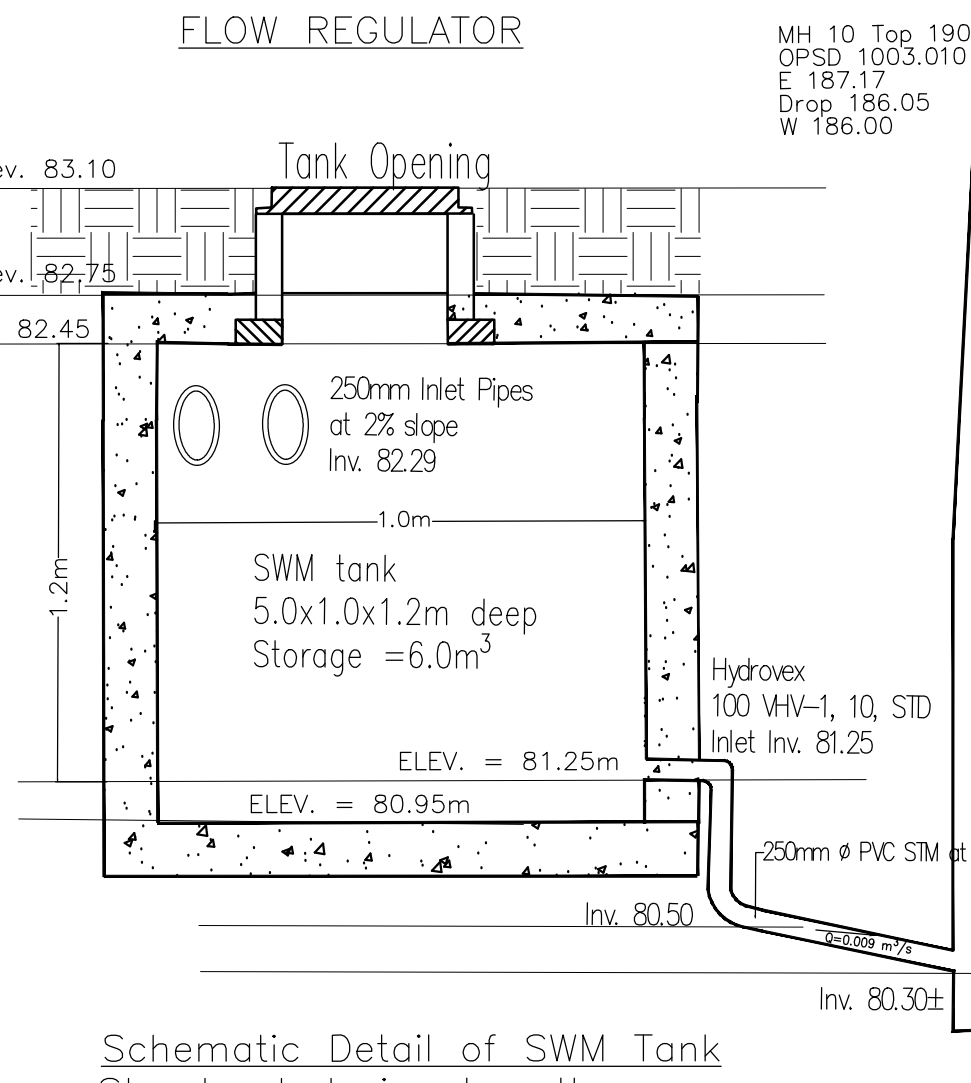
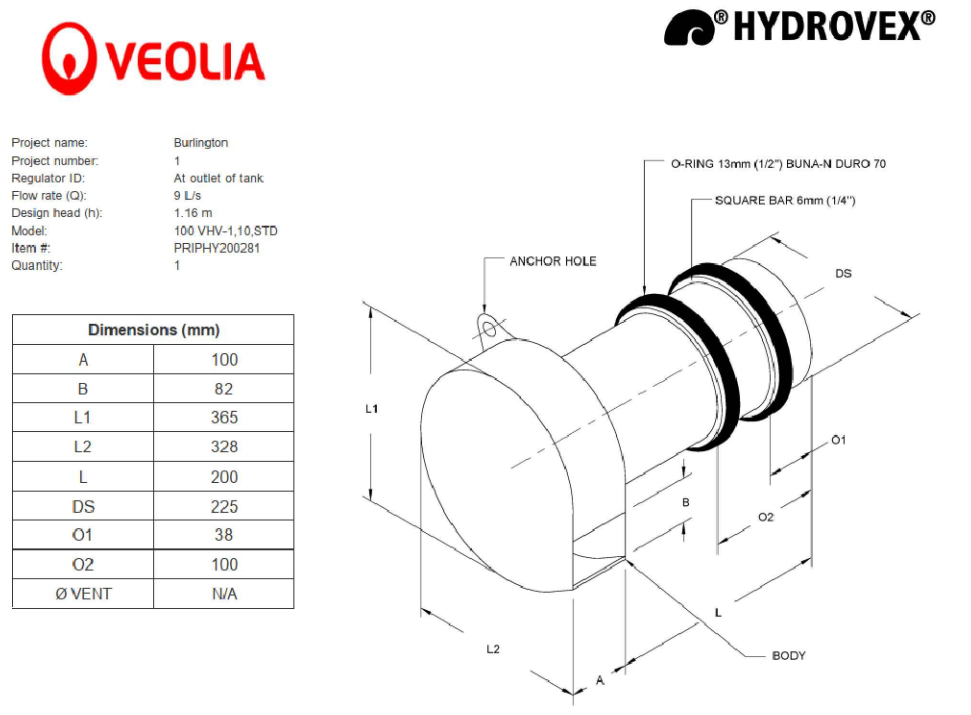
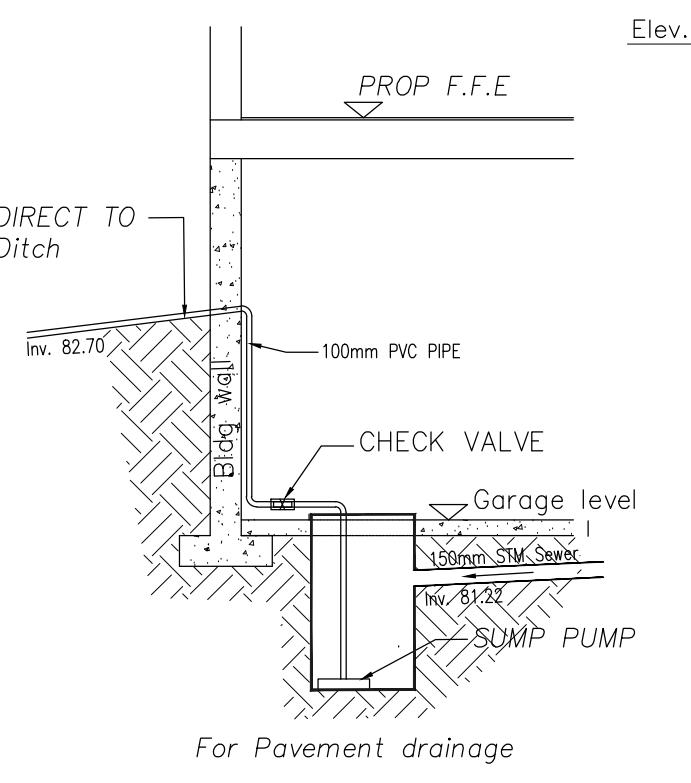
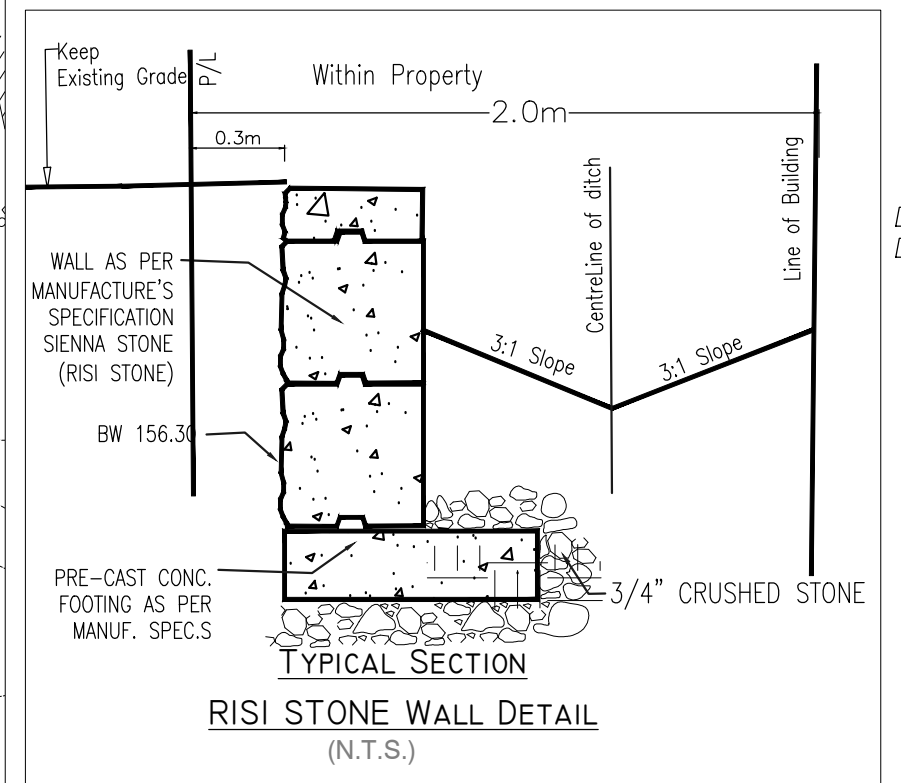

Key Plan

SURVEYOR'S REAL PROPERTY REPORT - PART 1
PLAN OF SURVEY OF
 LOTS 21 and 22
 and
 Part of LOT 23
 REGISTERED PLAN 169
 CITY OF BURLINGTON
 Regional Municipality of Halton
 SCALE 1:100

GTA SURVEYING INC.
 © COPYRIGHT 2022

BENCH MARK
 ELEVATIONS ARE GEODETIC AND ARE REFERRED TO THE CITY OF BURLINGTON BENCHMARK NO. 42, HAVING A PUBLISHED ELEVATION OF 82.015 METRES

LEGEND

1	EXISTING GRADE
2	PROPOSED GRADE
3	ENTRANCE & EXITS
4	PROPOSED FLOW PATHS
5	EXISTING FLOW PATHS
6	Scale

NO. DESCRIPTION DATE

1	City PRE-screen comments	June 17, 2023
2	City PRE-screen comments	June 29, 2023

DRAWING ISSUE AND REVISION NOTES

CONTRACTOR SHALL CHECK AND VERIFY ALL LAYOUT CONDITIONS, DIMENSIONS AND OTHER CONDITIONS WHICH AFFECT THE LAYOUT AND CONSTRUCTION OF THE WORK. CONTRACTOR SHALL REPORT ALL DIMENSIONAL AND/OR INFORMATION AND/OR INSTRUCTION DISCREPANCIES TO THE CONSULTANT BEFORE PROCEEDING WITH THE WORK. DRAWINGS ARE NOT TO BE SCALED. CONTRACT DOCUMENTS SHALL REMAIN THE PROPERTY OF THE CONSULTANTS AND SHALL BE RETURNED UPON COMPLETION OF THE PROJECT. NO PORTIONS OF THE CONTRACT DOCUMENTS MAY BE USED IN ANY FORM FOR ANY DESIGN AND/OR CONSTRUCTION PROJECT OTHER THAN THE PROJECT FOR WHICH THESE DOCUMENTS WERE ORIGINALLY PREPARED AND ISSUED BY THE CONSULTANTS.

OWNER

Ram Engineering Inc.
 1192 White Clover Way
 Mississauga, ON L5V 1K8
 Email: Ramdharamdial@gmail.com
 P: 905 567 1215

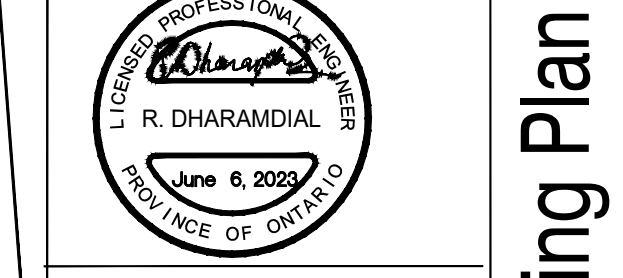

1238
 Bellview Street
 BURLINGTON
 ONTARIO

SP 1

ANTRIX
 ARCHITECTS
 1109 BRITANNIA ROAD EAST, MISSISSAUGA
 ON L4W 3X1, PHONE 905 564 1154
 FAX 888 501 0265

SERVICING AND GRADING
 PRELIMINARY DESIGN
 CAD FILE NAME:
 DRAWN/CHECKED: RD SCALE: 1:100
 DRAWING NO. DWG NAME:

Site Servicing and Grading Plan

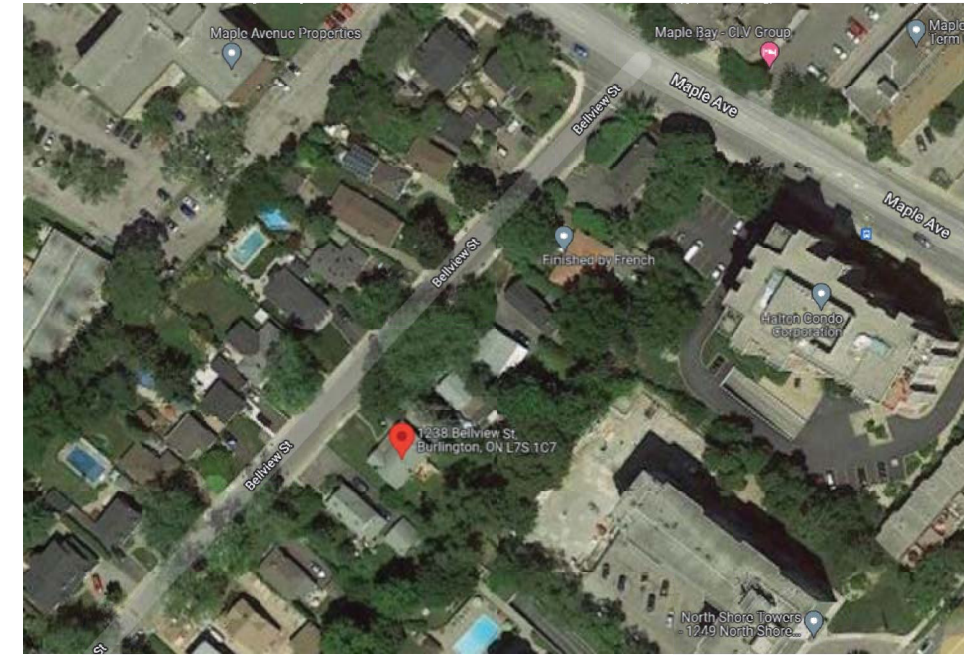
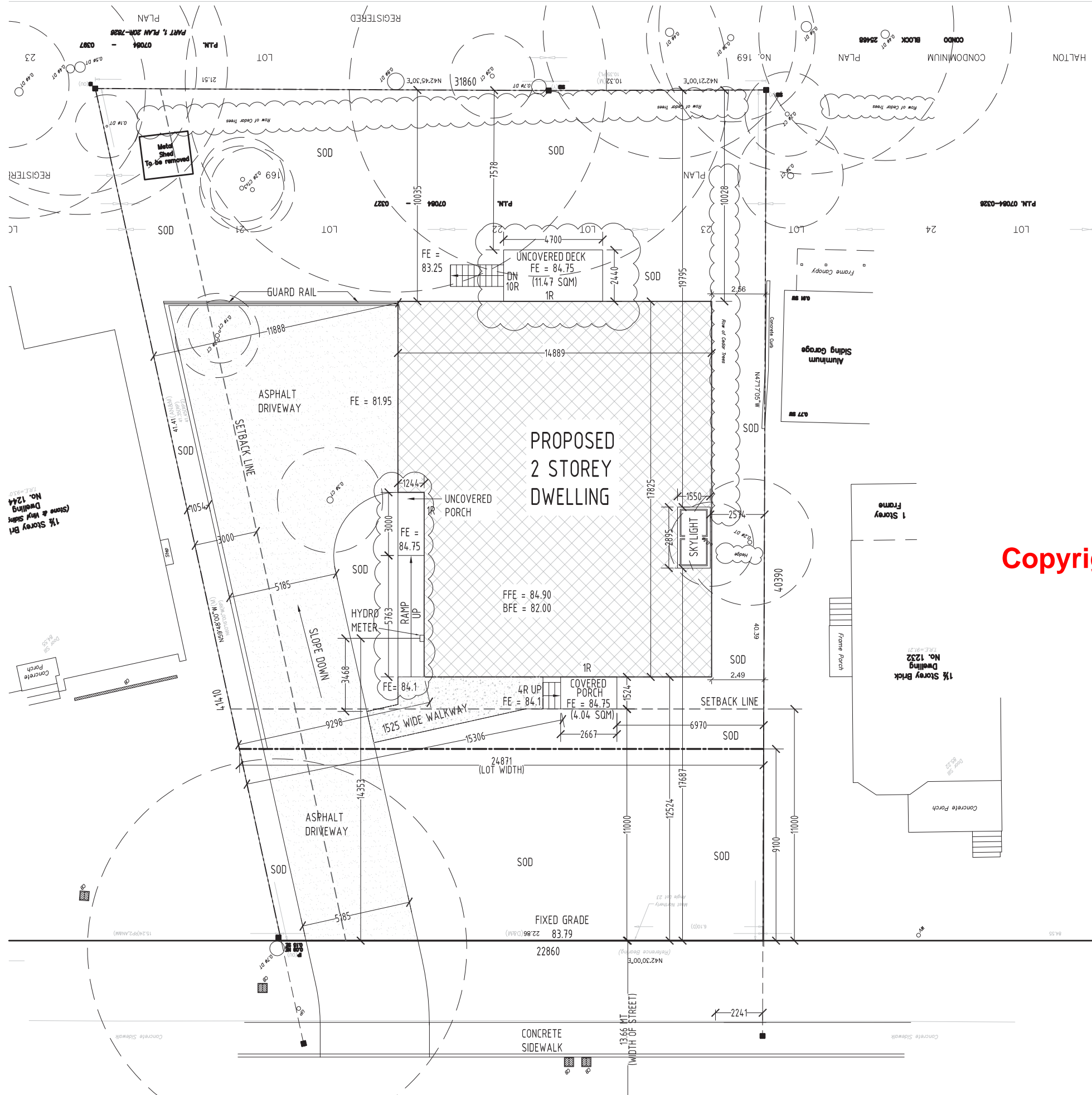

N
KEY PLAN
NTS

Copyright Act Applies to Use and Production

SITE STATISTICS

ZONE R2.1	PROPOSED/EXIST.	
	REQUIRED	PROPOSED/EXIST.
LOT AREA	700.00 SQM	1104.65 SQM
LOT WIDTH	18.00 M	24.85 M
FRONT YARD	11.00 M	11.00 M
REAR YARD	10.00 M	10.00 M
SIDE YARD (10% OF LOT WIDTH)	2.48 M	2.48 M
DWELLING DEPTH	18.00 M	17.83 M
LOT COVERAGE (25%)	276.16 SQM	274.07 SQM (23.01%)
FAR (0.45)	497.25 SQM	492.95 SQM (45%)
BUILDING HEIGHT	7.00 M	
BUILDING HEIGHT (ROOF)		7.00 M
BUILDING HEIGHT (PARAPET)		7.66 M
BUILDING HEIGHT (ROOF ACCESS)		8.67 M



SITE PLAN COMMENTS	MAR 17/26
MV APPLICATION	FEB 03/26
CONC. DECK, RAMP	DEC 23/25
HYDRO METER ADDED	JUL 21/25
AS PER APPROVED ZONING	NOV 26/23
SHED REMOVED	AUG 16/23
RESUBMISSION	JUN 01/23
PRE-CONSULTATION	MAR 24/23
PRE-CONSULTATION	OCT 15/22
PRE-CONSULTATION	OCT 15/22

PROPOSED SITE PLAN
SCALE 1:200



PROJECT
PROPOSED RESIDENCE
1238 BELLVIEW STREET, BURLINGTON, ONTARIO

ALL INFORMATION AND DIMENSIONS MUST BE CHECKED AND VERIFIED ON SITE. DO NOT SCALE DRAWINGS. ANY VARIANCES OR DISCREPANCIES MUST BE REPORTED TO THE DESIGNER PRIOR TO COMMENCEMENT OF THE WORK. ALL WORK SHALL BE CARRIED OUT IN ACCORDANCE WITH ALL BY-LAWS AND CODES HAVING JURISDICTION OVER THIS CONSTRUCTION SITE. THE DESIGN AND CONTRACT DRAWINGS ARE THE COPYRIGHT OF THE DESIGNER AND MAY NOT BE REPRODUCED, REUSED OR ALTERED WITHOUT THE WRITTEN PERMISSION OF THE DESIGNER.

DRAWN BY	NL
SCALE	1:200
PROJECT NO.	2205
DRAWING TITLE & NO.	PROPOSED SITE PLAN A1

Copyright Act Applies to Use and Production

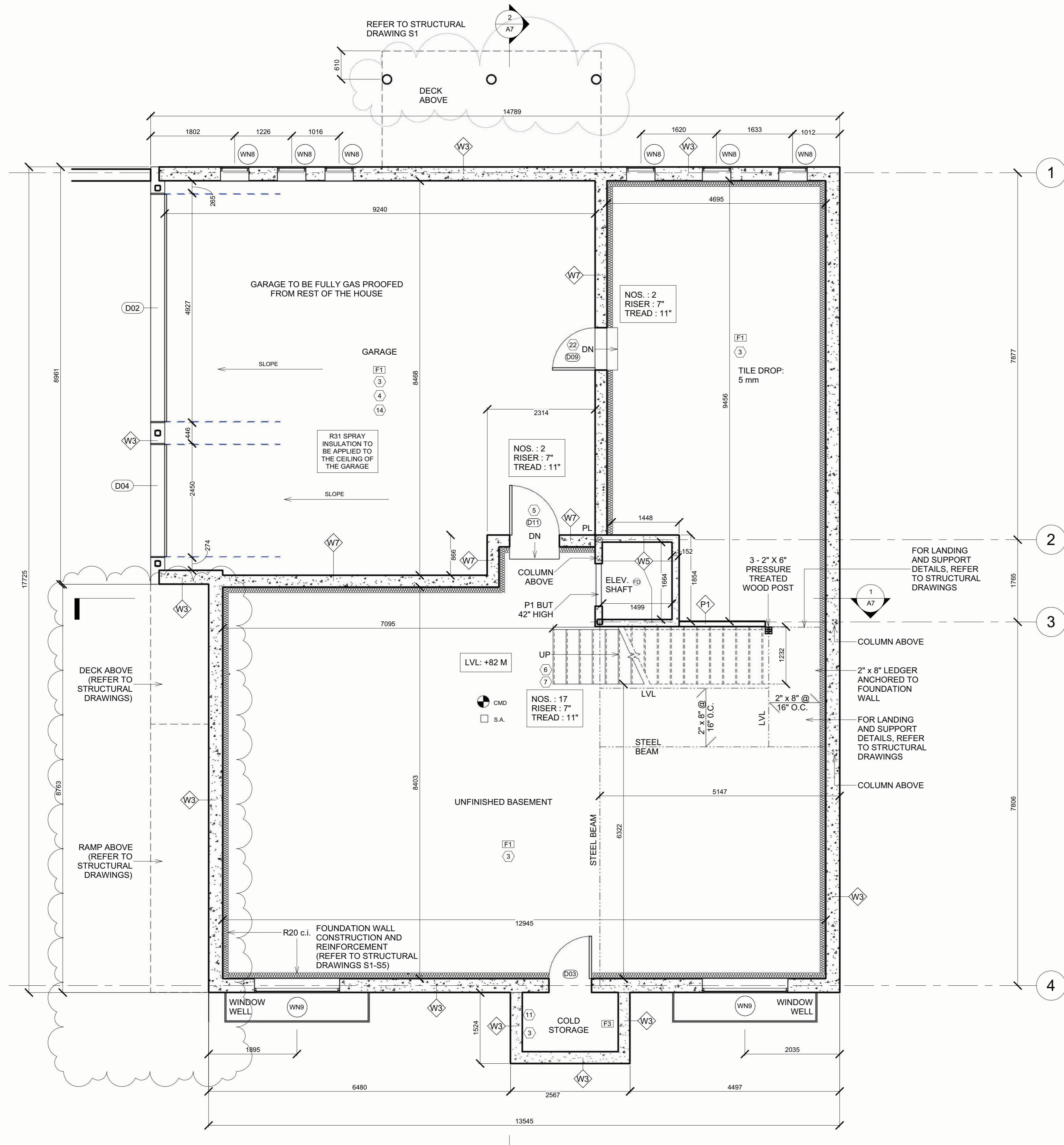

1 Basement Floor Plan
1:50
BASEMENT AREA = 254.57 SQM + 3.88 SQM = 258.45 SQM

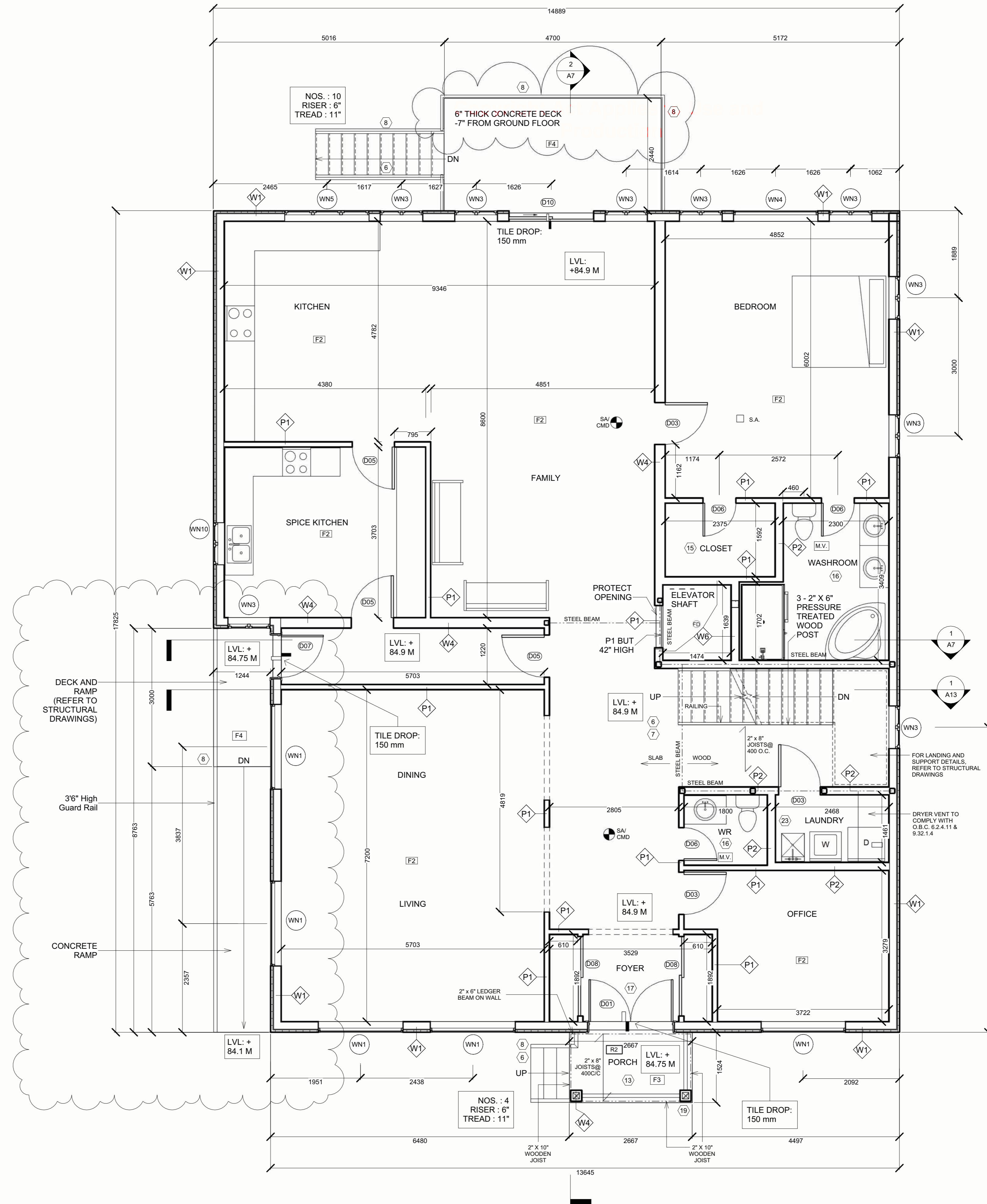

2 First Floor Plan
1:50
FIRST FLOOR AREA = 238.38 SQM



No.	Description	Date
1	Revision Review	Date: 2023
2	HEIGHT REVISED	Aug15,2023
3	ISSUED FOR REVIEW	Oct13,2023
4	ISSUED FOR REVIEW	Oct20,2023
5	ISSUED FOR REVIEW	Jan5,2023
6	ISSUED FOR REVIEW	Jan29,2023
7	GRADES REVISION	Apr17,2024
8	TERRACE SLAB REVISION	Apr24,2024
9	ISSUED FOR REVIEW	May23,2024
10	STAIRCASE REVISION	Sep04,2024
11	SKYLIGHT COMMENTS	Mar20,2026

Residence
1238 Bellview Street, Burlington
Basement Floor Plan & First Floor Plan
Project number 2205
Date 2026Mar20
Drawn by HL
Checked by SC

A3

Scale 1:50



ALL INFORMATION AND DIMENSIONS MUST BE CHECKED AND VERIFIED ON SITE. DO NOT SCALE DRAWINGS. ANY VARIANCES OR DISCREPANCIES MUST BE REPORTED TO THE DESIGNER PRIOR TO COMMENCEMENT OF THE WORK. ALL WORK SHALL BE CARRIED OUT IN ACCORDANCE WITH ALL BY-LAWS AND BUILDING CODES HAVING JURISDICTION OVER THIS CONSTRUCTION SITE. THE DESIGN AND CONTRACT DRAWINGS ARE THE COPYRIGHT OF THE DESIGNER AND MAY NOT BE REPRODUCED, REUSED OR ALTERED WITHOUT THE WRITTEN PERMISSION OF THE DESIGNER.

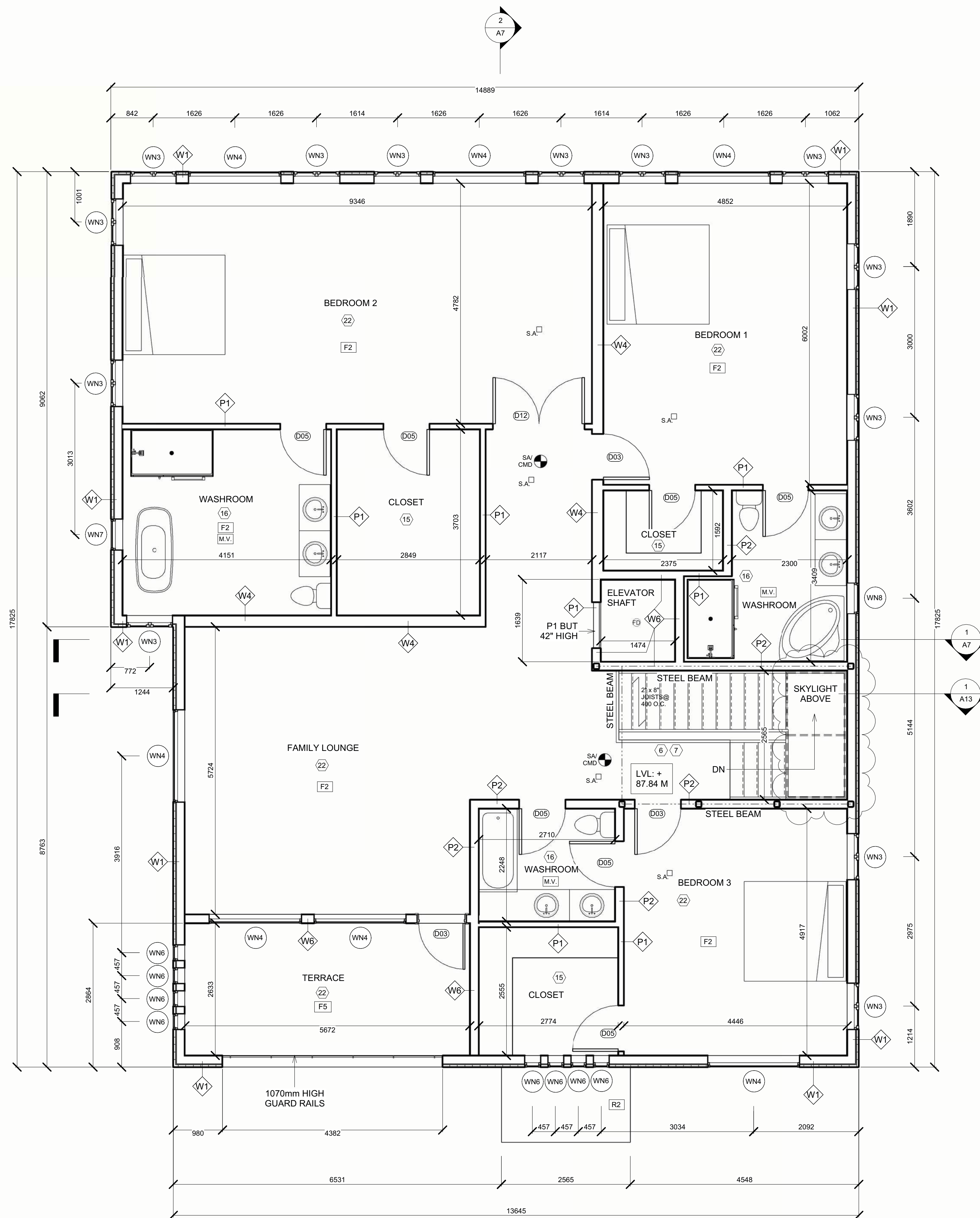

1 Second Floor Plan
1 : 50
SECOND FLOOR AREA = 238.38 SQM

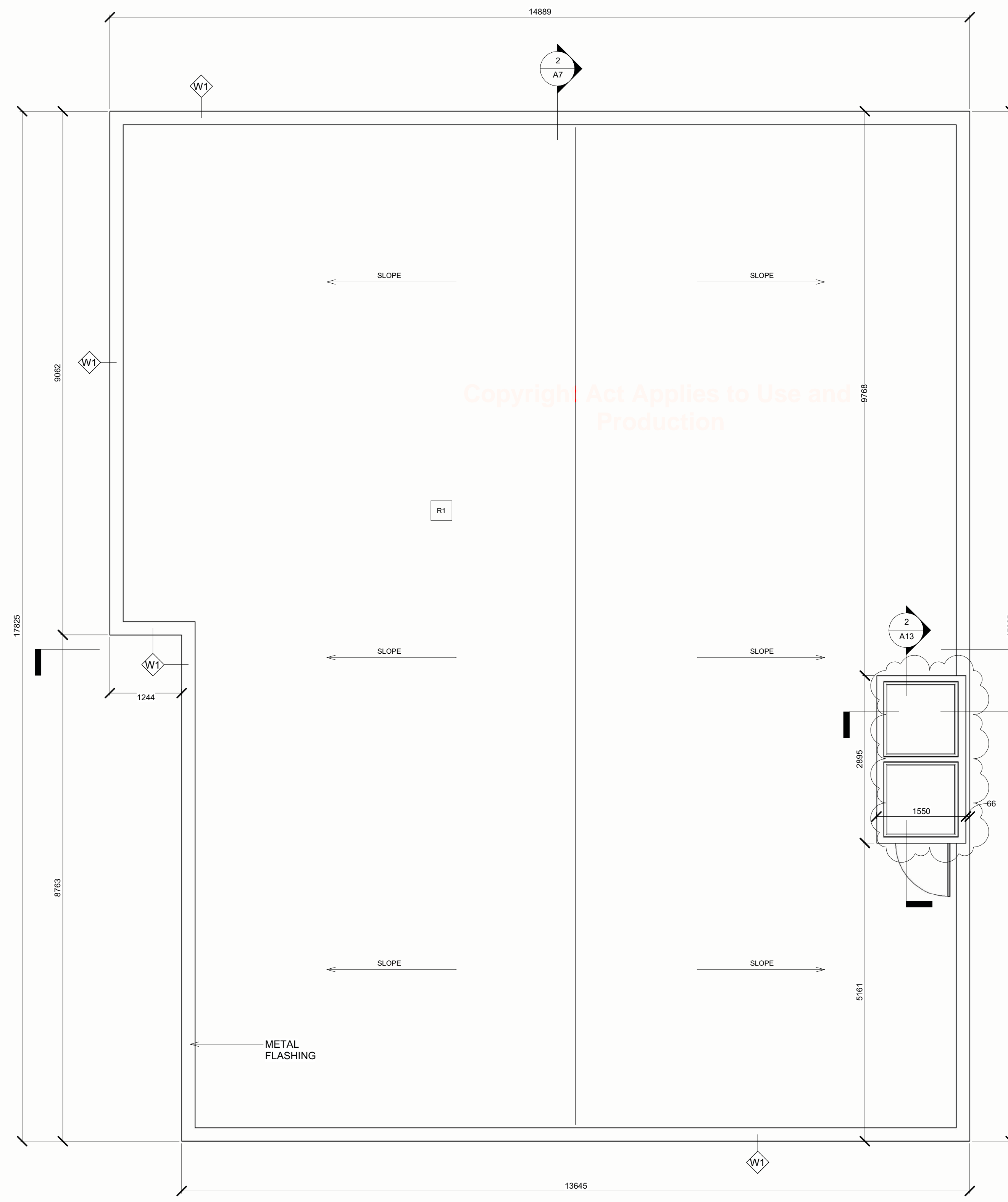

Copyright Act Applies to Use and Production

2 Roof Plan
1 : 50



No.	Description	Date
1	ISSUED FOR REVIEW	Oct11, 2023
2	HEIGHT REVISED	Aug15, 2023
3	ISSUED FOR REVIEW	Oct13, 2023
4	ISSUED FOR REVIEW	Oct20, 2023
5	ISSUED FOR REVIEW	Jan5, 2023
6	ISSUED FOR REVIEW	Jan29, 2023
7	GRADES REVISION	Apr17, 2024
8	TERRACE SLAB REVISION	Apr24, 2024
9	ISSUED FOR REVIEW	May23, 2024
10	ACM PANEL, CONCRETE DECK CONCRETE RAMP, ROOF ACCESS	Dec22, 2024

Residence

1238 Bellview Street, Burlington

Second Floor Plan & Roof Plan

Project number	2205
Date	2026Mar20
Drawn by	HL
Checked by	SC

A4

Scale 1 : 50

ANTRIX
ARCHITECTS INC.

1109 Britannia Road E, Mississauga,
Ontario L4W 3X1
O: 905 564 1154, M: 416 669 6564, 416 728 1807
www.antrix.ca

ALL INFORMATION AND DIMENSIONS MUST BE CHECKED AND VERIFIED ON SITE. DO NOT SCALE DRAWINGS. ANY VARIANCES OR DISCREPANCIES MUST BE REPORTED TO THE DESIGNER PRIOR TO COMMENCEMENT OF THE WORK. ALL WORK SHALL BE CARRIED OUT IN ACCORDANCE WITH ALL BY-LAWS AND BUILDING CODES HAVING JURISDICTION OVER THIS CONSTRUCTION SITE. THE DESIGN AND CONTRACT DRAWINGS ARE THE COPYRIGHT OF THE DESIGNER AND MAY NOT BE REPRODUCED, REUSED OR ALTERED WITHOUT THE WRITTEN PERMISSION OF THE DESIGNER.



No.	Description	Date
1	ISSUED FOR REVIEW	Jan21, 2023
2	HEIGHT REVISED	Aug15, 2023
3	ISSUED FOR REVIEW	Oct13, 2023
4	ISSUED FOR REVIEW	Oct20, 2023
5	ISSUED FOR REVIEW	Jan5, 2023
6	ISSUED FOR REVIEW	Jan29, 2023
7	GRADES REVISION	Apr17, 2024
8	TERRACE SLAB REVISION	Apr24, 2024
9	ISSUED FOR REVIEW	May23, 2024
10	ACM PANEL, CONCRETE DECK, CONCRETE RAMP, ROOF ACCESS	Dec22, 2025
11	ZONING COMMENTS	Jan27, 2026

Residence

1238 Bellview Street, Burlington

East Side & West Side Elevators

Project number 2205
 Date 2026Jan27
 Drawn by HL
 Checked by SC

A6

Scale 1 : 50



1109 Britannia Road E, Mississauga, Ontario L4W 3X1
 O: 905 564 1154, M: 416 669 6564, 416 728 1807
 www.antrix.ca

2026-01-27 5:16:37 PM

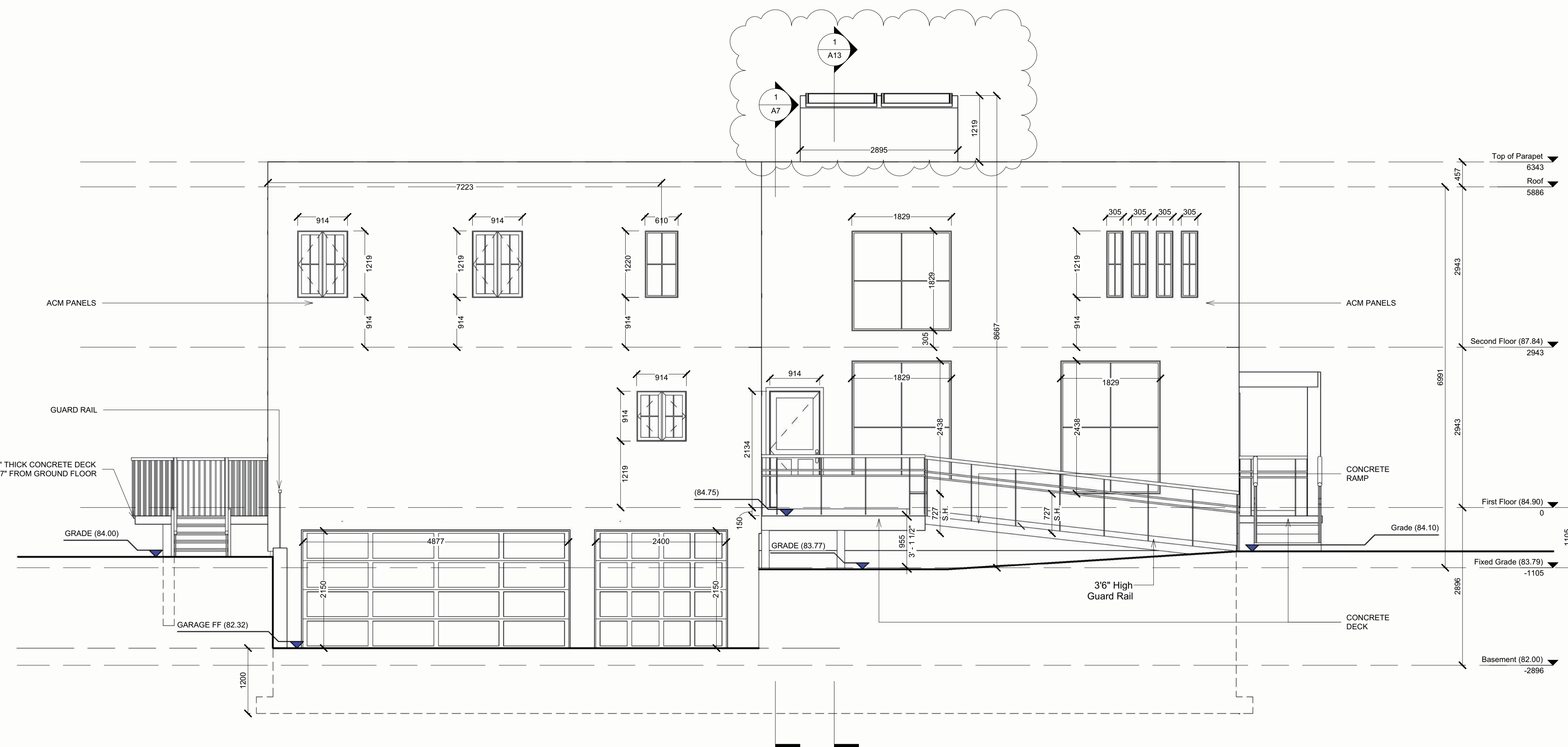

EAST ELEVATION (COMPARTMENT A)

EBF	60.59 m ²
LIMITING DISTANCE	10.1 m
ALLOWABLE OPENINGS	40%
OPENINGS PROVIDED	17.92 m ² (29.57%)

EAST ELEVATION (COMPARTMENT B)

EBF	76.73 m ²
LIMITING DISTANCE	9.5 m
ALLOWABLE OPENINGS	37%
OPENINGS PROVIDED	20.77 m ² (26.93%)

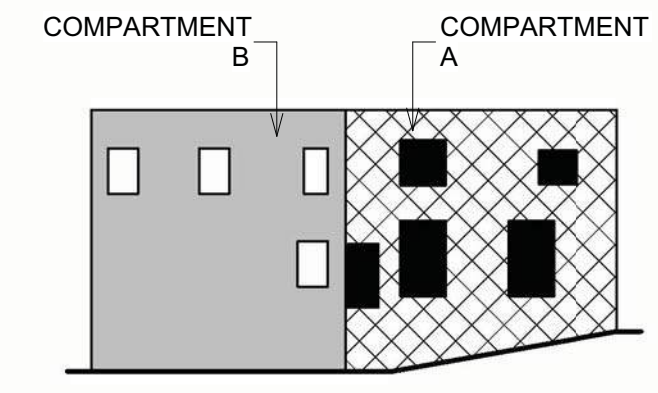

Copyright Act Applies to Use and Production

1 East Elevation
1 : 50

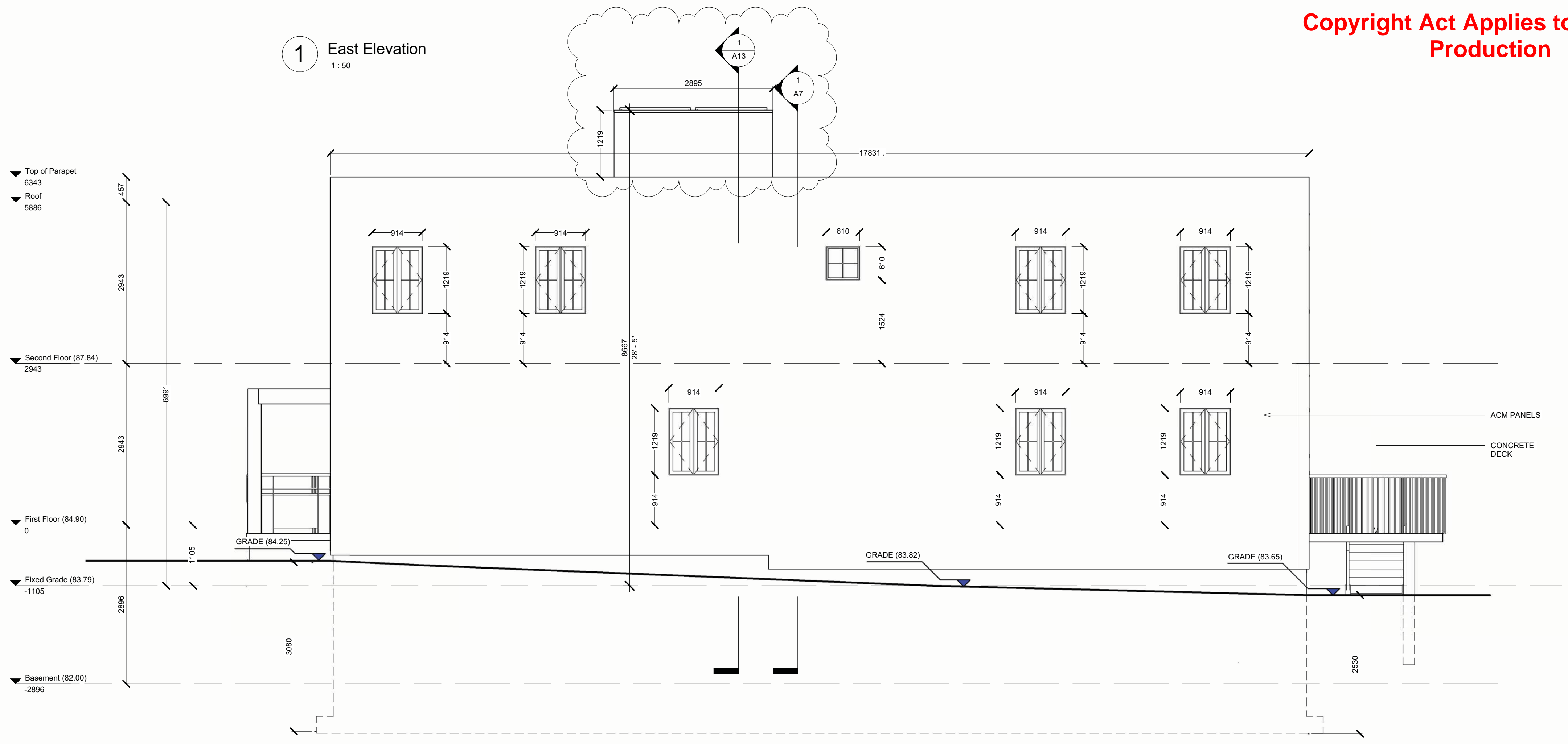

WEST ELEVATION

EBF	122.74 m ²
LIMITING DISTANCE	2.48 m
ALLOWABLE OPENINGS	8.96%
OPENINGS PROVIDED	10.12 m ² (8.24%)

2 West Elevation
1 : 50